



UNIVERSAL ROBOTS

User Manual

AI Accelerator





The information contained herein is the property of Universal Robots A/S and shall not be reproduced in whole or in part without prior written approval of Universal Robots A/S. The information herein is subject to change without notice and should not be construed as a commitment by Universal Robots A/S. This document is periodically reviewed and revised.

Universal Robots A/S assumes no responsibility for any errors or omissions in this document.

Copyright © 2009-2024 by Universal Robots A/S.

The Universal Robots logo is a registered trademark of Universal Robots A/S.



Contents

1. Introduction	6
1.1. About This Guide	6
1.2. Product Description	7
2. Safety	8
2.1. Safety Message Types	9
2.2. Validity and Responsibility	10
2.3. Limitation of Liability	10
2.4. General Warnings and Cautions	10
2.5. AI Accelerator Safety	13
3. Intended Use	14
4. Operating Environment	17
5. Declarations and Certificates (original EN)	18
6. Technical Specifications	19
7. Assembling the AI Accelerator	20
7.1. Camera	20
7.2. Attaching the Camera Mount	21
7.3. Camera cable	24
7.4. Compute Module	28
7.5. Tool Selection	28
8. Connectivity	30
9. Cybersecurity Threat Assessment	31
9.1. General Cybersecurity	31
10. Software	32
10.1. Installing the software	32
10.2. Camera Calibration	34
11. AprilTag	37
12. Demo: Object Classification	38
13. Demo: Table Pick and Place	40

1. Introduction

1.1. About This Guide

Description The purpose of this guide is to provide the essential information to start using the AI Accelerator.

Terminology This document combines terminology used in industrial robotics and AI research.

- Tool refers to the end effector such as a gripper.
- Part refers to the workpiece.
- Experiments refer to the trial exercises contained in this guide.

Assembling the AI Accelerator can require supervision by technically trained personnel.

Set up for the experimentation and demonstrations (demos) outlined in this guide can require a basic level of mechanical and electrical training.

In the box AI Accelerator shipped as a single box with the following parts inside:

- Compute module by Advantech, based on NVIDIA Jetson Orin
- Camera
- Camera mount
- Camera cable (USB-C with angled connector)
- Cable straps for camera cable (4 pcs)
- Tool flange bolts (4 pcs, 40 mm.)
- Calibration board
- This document

The following parts are necessary to complete the demo setup described in the section [10 Software on page 32](#) :

- Universal Robots e-Series robot (purchased separately)
 - Monitor, keyboard and mouse for Compute module setup
-

Business contact details Universal Robots A/S (hereinafter Universal Robots or UR)
Energivej 51, 5260 Odense S, Denmark
+45 89 93 89 89
<https://www.universal-robots.com>

1.2. Product Description

Description

AI Accelerator allows you to create robot applications by providing a PolyScope X integration with Perception and AI, including example code and data.

The AI Accelerator is a starter kit for developers and integrators, extending Universal Robots robot capabilities with:

- Computer vision and depth perception
- Additional computational power, for example to execute trainable neural networks, dynamic motion planning and traditional computer vision algorithms
- Capacity to make logical decisions based on camera and/or neural networks output

This kit can be integrated into different robot applications, where eventual use is defined by tools/end effectors, fixtures and software components.

Scripts are included to easily customize, build, deploy, debug and test full applications. The examples are generic and written for clarity. You can improve performance and optimize them for your particular needs later.

Frameworks are provided to allow you to simply integrate your own custom code.

The kit also includes tools to facilitate the use of cameras (camera connection check and hand-eye calibration).

2. Safety

Description

This chapter contains important safety information which must be read and understood **before** first use of the AI Robotics Kit

Read the general safety information and the instructions and guidance pertaining to the risk assessment and intended use provided. Give particular attention to text accompanied by warning symbols. Read and understand the specific engineering data relevant to mounting and installation in order to understand the integration of UR robots before the robot is powered on for the first time.

The integration and application of AI Accelerator requires risk assessment and risk reduction, even if the application remains undeployed.

- Always conduct a thorough risk assessment specific to your experiment and subsequent application.
- Reduce risks in accordance with the results of the risk assessment.



NOTICE

Universal Robots disclaims any and all liability if any part of the AI Accelerator is damaged, changed or modified in any way. Universal Robots cannot be held responsible for any damages caused to any equipment due to programming errors or malfunctioning of the components.



READ MANUAL

Read the manual for the robot **before** first use. Follow all safety precautions stated in the robot manual.

2.1. Safety Message Types

Description

Safety messages are used to emphasize important information. Read all the messages to help ensure safety and to prevent injury to personnel and product damage. The safety message types are defined below.



WARNING

Indicates a hazardous situation that, if not avoided, can result in death or serious injury.



WARNING: ELECTRICITY

Indicates a hazardous electrical situation that, if not avoided, can result in death or serious injury.



WARNING: HOT SURFACE

Indicates a hazardous hot surface where injury can result from contact and non-contact proximity.



CAUTION

Indicates a hazardous situation that, if not avoided, can result in injury.



GROUND

Indicates grounding.



PROTECTIVE GROUND

Indicates protective grounding.



NOTICE

Indicates the risk of damage to equipment and/or information to be noted.



READ MANUAL

Indicates more detailed information that should be consulted in the manual.

2.2. Validity and Responsibility

Description

The information in this manual does not cover designing, installing, integrating and operating a robot application, nor does it cover all peripheral equipment that can influence the safety of the robot application.

The robot application must be designed and installed in accordance with the safety requirements set forth in the relevant standards and regulations of the country where the robot is installed.

The person/s integrating the AI Accelerator are responsible for ensuring the applicable regulations in the country concerned are observed and that any risks in the robot application are adequately reduced. This includes, but is not limited to:

- Performing a risk assessment for the complete robot system
 - Interfacing other machines and additional safeguarding if required by the risk assessment
 - Setting the correct safety settings in the software
 - Ensuring safety measures are not modified
 - Validating the robot application is designed, and installed and integrated
 - Specifying instructions for use
 - Marking the robot installation with relevant signs and contact information of the integrator
 - Retaining all documentation; including the application risk assessment, this manual, robot manual and additional relevant documentation.
-

2.3. Limitation of Liability

Description

Any information provided in this manual must not be construed as a warranty, by UR, that the industrial robot will not cause injury or damage, even if the industrial robot complies with all safety instructions and information for use.

2.4. General Warnings and Cautions

Description

The following warnings messages can be repeated, explained or detailed in subsequent sections.

**WARNING**

Failure to adhere to the general safety practices, listed below, can result in injury or death.

- Verify the robot arm, camera mount, and tool/end effector are properly and securely bolted in place.
- Verify the robot application has ample space to operate freely.
- Verify the personnel are protected during the lifetime of the robot application including transport, installation, commissioning, programming/ teaching, operation and use, dismantling and disposing.
- Verify robot safety configuration parameters are set to protect personnel, including those who can be within reach of the robot application.
- Avoid using AI Accelerator if any of its parts are damaged.
- Avoid wearing loose clothing or jewelry when working with the robot. Tie back long hair.
- Avoid placing any fingers behind the internal cover of the Control Box.
- Inform users of any hazardous situations and the protection that is provided, explain any limitations of the protection and the residual risks.
- Inform users of the location of the emergency stop button(s) and how to activate the emergency stop in case of an emergency or an abnormal situation.
- Warn people to keep outside the reach of the robot, including when the robot application is temporarily inactive (waiting).
- Be aware of robot orientation to understand the direction of movement when using the Teach Pendant.
- Adhere to the requirements and guidance in ISO 10218-2.

**WARNING**

Handling tools/end effectors with sharp edges and/or pinch points can result in injury.

- Make sure tools/end effectors have no sharp edges or pinch points.
- Protective gloves and/or protective eyeglasses could be required.

WARNING: HOT SURFACE

Prolonged contact with the heat generated by the robot arm, Compute module, and the Control Box, during operation, can lead to discomfort resulting in injury.

- Do not handle or touch the robot while in operation or immediately after operation.
- Check the temperature on the log screen before handling or touching the robot.
- Allow the robot to cool down by powering it off and waiting one hour.

CAUTION

Failure to perform a risk assessment prior to integration and operation can increase risk of injury.

- Perform a risk assessment and reduce risks prior to operation.
- If determined by the risk assessment, do not enter the range of the robot movement or touch the robot application during operation. Install safeguarding.
- Read the risk assessment information.

CAUTION

Using the robot with untested external machinery, or in an untested application, can increase the risk of injury to personnel.

- Test all functions and the robot program separately.
- Read the commissioning information.

NOTICE

Very strong magnetic fields can damage the robot.

- Do not expose the robot to permanent magnetic fields.

READ MANUAL

Verify all mechanical and electrical equipment is installed according to the specifications and warnings found in the **Mechanical Interface** and in the **Electrical Interface** sections of the robot User Manual.

2.5. AI Accelerator Safety

AI Accelerator The AI Accelerator allows AI to work in conjunction with vision and sensor feedback to make logical decisions about the robot arm's behavior.



WARNING

There can be additional risks associated with AI making decisions regarding robot arm behavior with potential for unintended consequences, safety hazards, and system failures.

- Be aware of the risk of sudden and unexpected motions due to the AI decisions.
- Be aware of the risk of unpredictable motion patterns.
- Restrict the amount of personnel traffic within reach and around the robot application when the application is running an AI experiment or demo.



WARNING

Prolonged robot inactivity can be perceived as a stop, resulting in equipment damage or personnel injury due to unexpected movement, or a sudden start.

- The person developing an application shall be responsible for installing and programming AI Accelerator, to lessen unexpected movement situations.
- Check the program state to determine if the robot is completely stopped or temporarily inactive (waiting). If the program is running but the robot is not moving, the robot can move again unexpectedly.



WARNING

Failure to turn off, secure and lock out all sources of hazardous energy to the robot application when servicing, or repairing, any part of the AI Accelerator set-up can result in death or serious injury due to unexpected movement.

- Turn off, secure and lock out sources of hazardous energy before conducting all service and repair procedures.

3. Intended Use

Description

The AI Accelerator is intended to create robot applications using Perception, AI and PolyScope X integration solution.

Possible applications of AI Accelerator are limited by combination of the technical specifications of its components. Consult technical specification of individual components to determine their suitability for a purpose.

For details about the conditions under which the robot should operate, see Declarations and Certificates and the technical specifications in the robot **User Manual**.

All UR robots are equipped with safety functions, which are purposely designed to enable collaborative applications, where the robot application operates together with a human. The safety function settings must be set to the appropriate values as determined by the robot application risk assessment.

Collaborative applications, without guards or protective devices, are only intended for non-hazardous applications, where the complete application, including tool/end effector, work piece, obstacles and other machines, is low risk according to the risk assessment of the specific application.



WARNING

The AI Accelerator shall not be used with CB3 robots or PolyScope versions prior to 10.7.1.

- Only use AI Accelerator with UR e-Series robots running PolyScope X 10.7.1 or later.

**WARNING**

Using UR robots or UR products outside of the intended uses can result in injuries, death and/or property damage. Do not use the UR robot or products for any of the below unintended uses and applications:

- Medical use, i.e. uses relating to disease, injury or disability in humans including the following purposes:
 - Rehabilitation
 - Assessment
 - Compensation or alleviation
 - Diagnostic
 - Treatment
 - Surgical
 - Healthcare
 - Prosthetics and other aids for the physically impaired
 - Any use in proximity to patient/s
- Handling, lifting, or transporting people
- Any application requiring compliance with specific hygienic and/or sanitation standards, such as proximity or direct contact with food, beverage, pharmaceutical, and /or cosmetic products.
 - UR joint grease can be released into the air (vapor), or drip.
- Any use, or any application, deviating from the intended use, specifications, and certifications of UR robots or UR products.
- Misuse is prohibited as the result could be death, personal injury, and /or property damage

UNIVERSAL ROBOTS EXPRESSLY DISCLAIMS ANY EXPRESS OR IMPLIED WARRANTY OF FITNESS FOR ANY PARTICULAR USE.

**WARNING**

- The AI Accelerator is designed for use in standard industrial environments and is sold “AS-IS”. Universal Robots makes no declaration of conformity, claim of functionality, or fitness for particular purpose to the extent the AI Accelerator is used beyond the prescribed intended use.
- The user shall ensure that the AI Accelerator is at all times used in full compliance with all applicable regulatory and legal requirements. If the user utilizes the AI Accelerator for applications outside the intended use, the user shall bear sole and exclusive liability.

**READ MANUAL**

Failure to use the AI Accelerator in accordance with the intended use can result in unsafe situations.

- Read and follow the recommendations for intended use provided in this manual.

4. Operating Environment

Description

Special precautions should be taken when using components of the AI Accelerator in industrial environment.

Consider summary of the factors, such as ingress prevention rating for each of the components, the airflow requirements and ambient temperature range. See [6 Technical Specifications on page 19](#) and **Technical Specifications** section in Robot User Manual.



WARNING: ELECTRICITY

Failure to follow any of the below can result in serious injury or death due to electrical hazards.

- Make sure all equipment not rated for water exposure remain dry. If water is allowed to enter the product, lockout-tagout all power and then contact your local Universal Robots service provider for assistance.

5. Declarations and Certificates (original EN)



EU Declaration of Incorporation (DOI) (in accordance with 2006/42/EC Annex II B)

original EN

Manufacturer:	Person Authorized to Compile the Technical File:	
Universal Robots A/S Energivej 1 DK-5260 Odense S Denmark	David Brandt Technology Officer, R&D Universal Robots A/S, Energivej 51, DK-5260 Odense S	
Description and Identification of the product:		
Product and Function:	<p>AI Accelerator consists of software, camera, camera mount, camera mounting accessories, bolts to attach the mount to a UR robot tool flange and a camera calibration. The UR AI Accelerator is only intended for use with the Universal Robots e-Series robots, which has its own DOI.</p> <p>The box includes a computational module Advantech NVIDIA Jetson Orin covered by their DOI: https://buy.advantech.eu/Compact-Tower-Systems/AI-Jetson-Platforms-Edge-AI-Computer-Systems/model-MIC-733-AO6A1.htm</p> <p>See the above link for the Advantech NVIDIA declaration.</p>	
Model:	AI Accelerator	
Serial Number:	<p>Starting 24XX 200550 01 0001 and higher</p> <p>year month Sequential numbering, restarting at 0 each year Revision number, starting 01</p>	
Incorporation:	<p>The UR AI Accelerator shall only be put into service upon being integrated into a final complete machine (robot application or robot cell), which conforms with the provisions of the Machinery Directive and other applicable Directives.</p>	
<p>It is declared that the above products fulfil, for what is supplied, the following directives as detailed below: When this component is integrated into and becomes part of a complete machine, the integrator is responsible for the completed machine fulfilling all applicable Directives, applying the CE mark and providing the Declaration of Conformity (DOC).</p>		
I. Machinery Directive 2006/42/EC	<p>The following essential requirements have been fulfilled: 1.1.2, 1.1.3, 1.2.6, 1.3.4, 1.5.1, 1.7.2, 1.7.4, Annex VI.</p> <p>It is declared that the relevant technical documentation has been compiled in accordance with Part B of Annex VII of the Machinery Directive.</p>	
II. Low-voltage Directive 2014/35/EU	Reference the Directive and the harmonized standards used below.	
Reference to the harmonized standards used, as referred to in Article 7(2) of the MD & LV Directives and Article 6 of the EMC Directive:		
(I) EN ISO 10218-1:2011 as applicable	(I) EN ISO 13850:2015 as applicable	(I) (II) EN 60204-1:2018 as applicable
(I) EN ISO 13849-1:2015 as applicable	(I) EN ISO 14118:2017 as applicable	
The manufacturer, or his authorised representative, shall transmit relevant information about the partly completed machinery in response to a reasoned request by the national authorities.		
Approval of full quality assurance system for Universal Robots by the notified body Bureau Veritas: ISO 9001 certificate #DK015892 and ISO 45001 certificate #DK015891.		

Odense Denmark, 22 November 2024

Roberta Nelson Shea, Global Technical Compliance Officer

Universal Robots A/S, Energivej 51, DK-5260 Odense S, Denmark
CVR-nr. 29 13 80 60

Phone +45 8993 8989
Fax +45 3879 8989

info@universal-robots.com
www.universal-robots.com

6. Technical Specifications

Package dimensions	350 x 300 x 260 mm
Package weight	5 kg
Compute module	NVIDIA Jetson Orin Advantech MIC-733-AO 64Gb, 1Tb SSD
Compute module IP classification	IP40
Compute module operating temperature	-10 ~ +60 °C with 0.7 m/s airflow (MaxN mode)
Compute module operating humidity	95% @ 40 °C (non-condensing)
Camera	Orbbec Gemini 335Lg
Camera IP classification	IP67
Camera mount	Tool flange extender and camera bracket
Camera mount weight	300 gr
Camera mount material	Aluminium
Camera cable	Amphenol RF 5 m.
Cable guides material	Velcro® polypropylene and velour PA
Calibration board	8x7 nodes, 15 mm checker size

7. Assembling the AI Accelerator

- Description** Complete assembly of AI Accelerator requires the following steps:
1. Mounting the robot
 2. Attaching camera mount and optionally an end effector (See [Attaching the Camera Mount](#))
 3. Affixing camera cable (See [Camera cable](#))
 4. Connecting Ethernet cables
 5. Connecting power cables
-

Mounting the robot For mechanical and electrical installation instructions of the robot arm and the Control Box, refer to the robot **User Manual**.

7.1. Camera

Description The main options for camera mounting in the robot machine vision application are: robot-mounted or fixed-mounted. The camera mount included in AI Accelerator allows camera to be mounted on Universal Robots robot arms.

Camera mount The AI Accelerator camera mount is designed to be inserted between the robot tool output flange and the end effector. Before mounting the camera, familiarize yourself with the **Securing Tool** section of the **Mechanical Interface** chapter in the robot User Manual and mounting instructions that came with the selected end effector.

Assembly

The camera mount is supplied pre-assembled. To attach camera to the mount:

1. Remove camera from the packaging.
2. Point the connector on the camera towards the tool flange adapter.
3. Use two M4 screws to attach camera to the holder.
4. Align camera cable along the grooves on the camera holder and attach it with wire ties.

**Camera cable**

Chapter [Camera cable](#) explains how to arrange the cable connecting the camera to compute module, externally along the robot arm.

7.2. Attaching the Camera Mount

Securing the Robot Arm

Read the **Mechanical Interface** section in robot User Manual.

Before attaching the camera you should mount the robot arm according to the requirements specific to your robot model as described in **Securing the Robot Arm** chapter in robot User Manual. You can test the robot movement without any attachments.

End of Arm

Read the **Securing Tool** chapter in robot User Manual.

Supplied with the kit you will find four M6 bolts. Bolts in the kit are suitable for attaching the camera mount without an end effector.

Camera mount could be inserted between the robot tool flange connector and an end effector using longer bolts.

**CAUTION**

Very long M6 bolts can press against the bottom of the tool flange and short circuit the robot.

- Do not use bolts that extend beyond 10 mm to mount the tool.

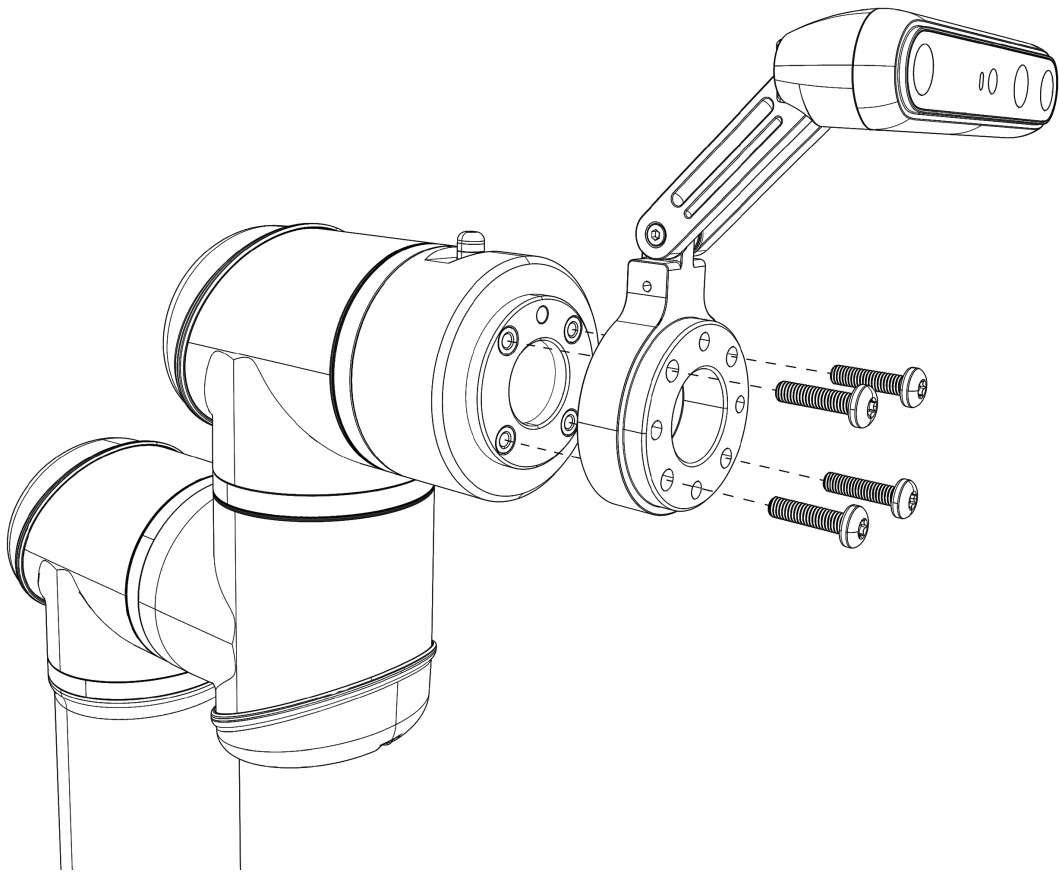

Correct payload**CAUTION**

Incorrect payload can result in unexpected robot movement when entering Freedrive.

- Remember to set the correct payload on the robot and adjust the Center of Gravity (CoG).

As a guidance, assembled camera mount, camera and mounting bolts weight approximately 480 gr.

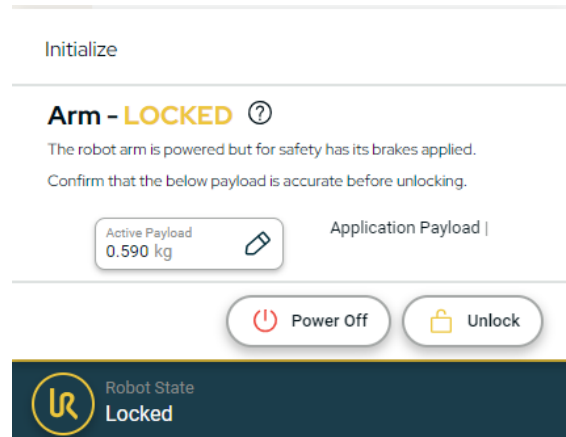

Adjusting the camera mount

Robot vision applications require consistent camera positioning, either fixed to the robot arm or static relative to the robot base.

To ensure the necessary rigidity, camera mount parts are secured with locking pins, which prevent accidental changes to the camera position. Adjusting the camera position requires disassembling the camera mount, realigning the parts, and reassembling them.

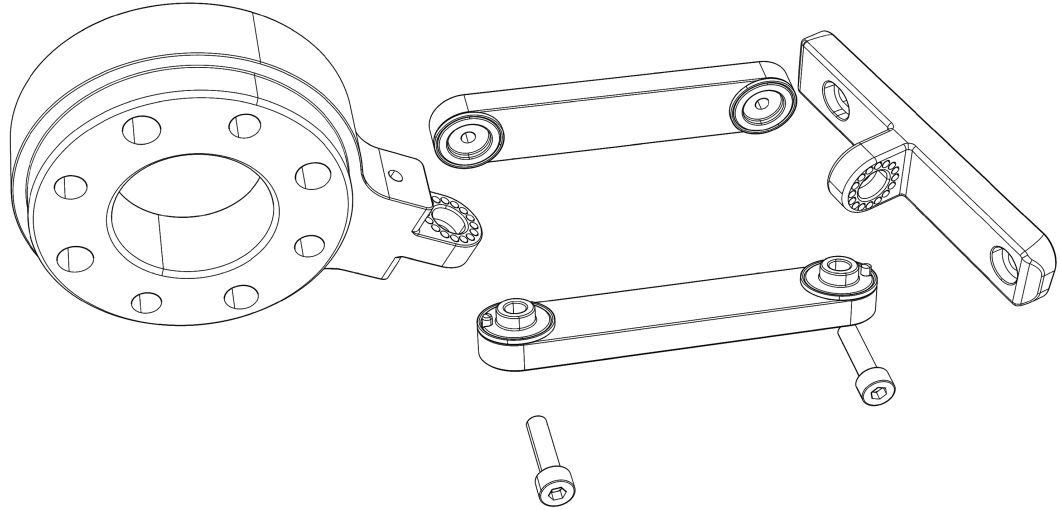
**CAUTION**

Do not attempt to adjust camera position by forcing camera mount parts.

**CAUTION**

Repeat camera calibration after adjusting camera position.
See [10.2 Camera Calibration](#) on page 34.

7.3. Camera cable

Description**CAUTION**

Your robot should be mounted and powered off before attaching the external cable and end effector.

External cables can create risks of entanglement for the operator or interfere with robot operation.

Cables can be damaged by the robot motion and create additional hazards.

Care must be taken when affixing external cables that these risks are mitigated.

- Restrict range of possible joint movement to prevent damage to the camera cable.

To affix the camera cable

While robot joints can rotate plus and minus 360 degrees from the zero position, this movement will damage the camera cable and in practice is not required in most applications.

The safety functions of the robot can be used to limit the motions range of the joint. Refer to the robot **User Manual** for descriptions of how to use the safety functions.

1. Before affixing the cable, pose the robot to the median position of all movements necessary for your application.
2. Attach the camera cable to the camera.
3. Make loose coil around wrist joints of the robot arm. Run the remainder of the cable along the arm.
4. Use cable straps to fix cable to the upper part of the arm. Make sure that the cable is not under the buckles of the cable straps.
5. Leave some loose cable between the two tubes of the robot arm and fix the cable to the bottom part of the arm.
6. Connect the camera cable to compute module.

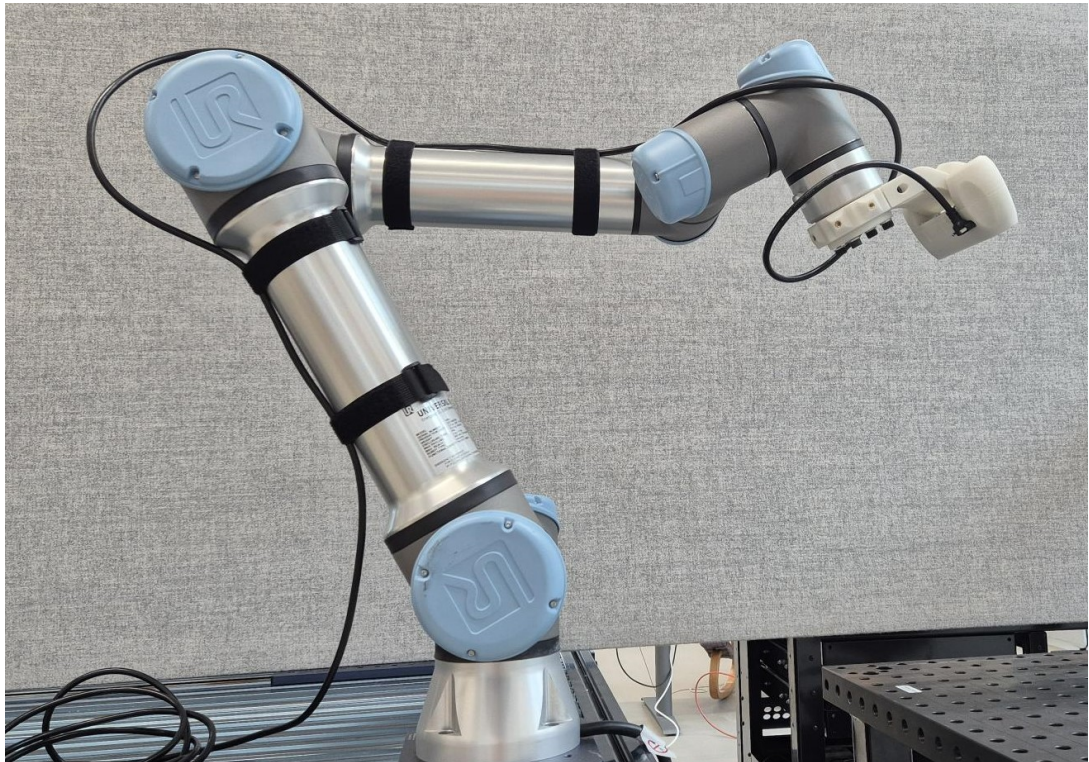

Restricting joint movement

When the camera cable is attached to the robot, you can restrict joint movement. Before continuing you should familiarize yourself with robot **Freedrive**, refer to the robot User Manual.

To restrict joints movement:

1. In PolyScope open 3D View and **Joints** tab.
2. Start the robot arm, unlock the brakes and start Freedrive.
You may want to move the Freedrive restrictions panel to make joint angles visible.
3. While in Freedrive, slowly move robot arm from side to side, imitating robot movement in your application.
4. Observe the camera cable and give cable more slack or reposition cable coils if necessary.
5. Move robot to most extreme positions of your application and take note of the joint angles for each joint.
6. Enter these values as **Joint Positions** in **Joint Limits** of the **Safety** settings of your robot.

Read robot User Manual, **Safety** section on how to enter joint restrictions in PolyScope X.

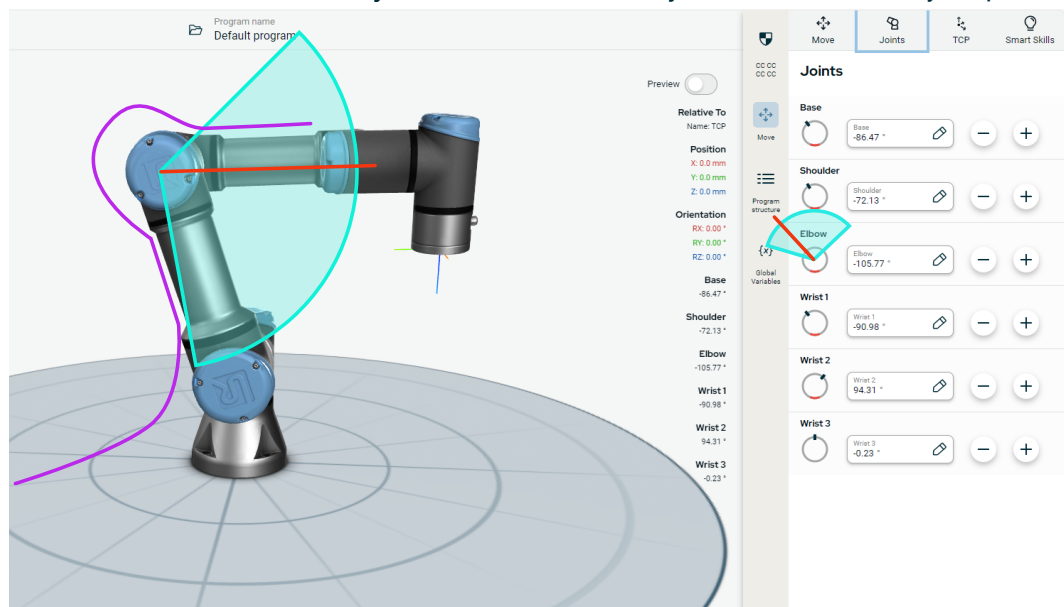

Testing joint limits

Try to move robot using the **Move** tab and verify that camera cable is not overtightened or clamped by possible robot movements.

7.4. Compute Module

Description AI Accelerator includes Compute module based on NVIDIA Jetson Orin.



READ MANUAL

Read the NVIDIA Jetson Orin manual and follow all safety instructions.

Compute Module position When positioning the Compute Module, ensure the following:

- The Compute Module is placed in a clean and dry space with sufficient airflow.
- The cable from the 3D camera can reach the Compute Module.

7.5. Tool Selection

Description The AI Accelerator does not provide a tool or end effector. You need to choose the correct end effector for your set up/work cell. Tool choice can depend on different requirements including:

- Purpose
- Weight
- Connections

Purpose A gripper type end effector, like a vacuum or finger gripper, is the most common tool for moving objects around. Verify this gripper works with Universal Robots software PolyScope X.

Weight The total weight of the camera module, gripper and work part shall not exceed the maximum payload of your robot.

Connections The selected end effector should use tool flange output for communicating with the robot. Running an additional external cable or pneumatic pipe for a vacuum gripper can complicate your application.

Make sure your selected end effector does not obscure camera vision. You can rotate camera around tool flange adapter if necessary.



CAUTION

Remember to adjust payload and TCP settings after change of tooling.

8. Connectivity

Description

This section describes the connection of the components of the AI Accelerator



WARNING: ELECTRICITY

Do not use any cables if they are damaged or show signs of wear.

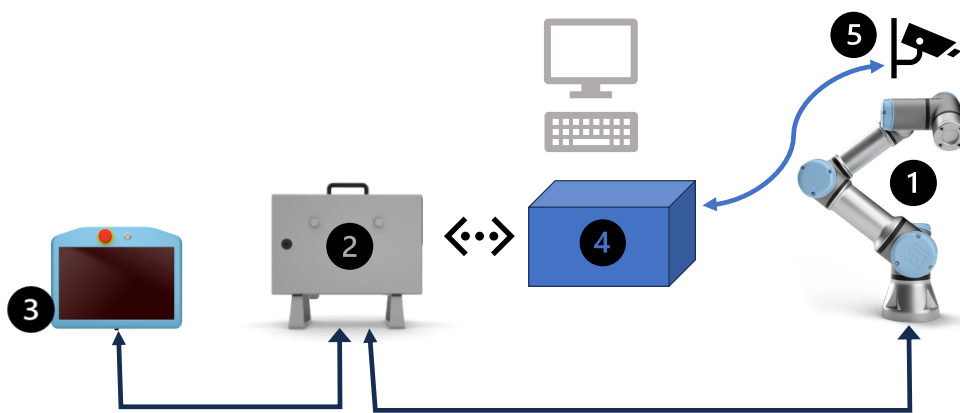

1. **Robot Arm**
Connected to Control Box with proprietary cable.
2. **Control Box**
Connected to the mains power (not shown).
3. **Teach Pendant**
Connected to the Control Box with proprietary cable.
4. **Compute module**
Connected to Control Box via Ethernet connection. Initial setup requires monitor, keyboard and mouse (not included).
5. **Camera**
Connected to Compute module with supplied camera cable.

9. Cybersecurity Threat Assessment

9.1. General Cybersecurity

Description

Connecting components of AI Accelerator to a network can introduce cybersecurity risks. These risks can be mitigated by using qualified personnel and implementing specific measures for protecting the robot's cybersecurity.

Implementing cybersecurity measures requires conducting a cybersecurity threat assessment.

The purpose is to:

- Identify threats
- Define trust zones and conduits
- Specify the requirements of each component in the application



WARNING

Failure to conduct a cybersecurity risk assessment can place the robot at risk.

- The integrator or competent, qualified personnel shall conduct a cybersecurity risk assessment.



NOTICE

Only competent, qualified personnel shall be responsible for determining the need for specific cybersecurity measures and for providing the required cybersecurity measures.



READ MANUAL

Read the robot User Manual sections **Cybersecurity Requirements** and **Cybersecurity Hardening Guidelines**.

10. Software

Description

AI Accelerator uses ROS messaging for two-way communication between the Docker software run by the Compute module and the URCap running in robot's controller.

Before running the software installation and configuration scripts, make sure all hardware is correctly connected.

1. Robot's control box and Compute module must be on the same network.
2. Camera cable is plugged in to Compute module.
3. Robot's control box is powered on and PolyScope X started.

The brakes in the robot arm can remain engaged until you proceed to calibration or other activities requiring robot movement.

Correct time settings

Time synchronization and time stamp is extensively used by components of AI Accelerator. Therefore it is important to set correct time in robot's controller and compute module.

Hardware permissions

Host OS on the compute module must have permissions to use USB ports. This is necessary for communicating with the camera.

Make sure that the camera is connected to the compute module before running install and post-install scripts.

10.1. Installing the software

Description

The compute module of the AI Accelerator comes with pre-installed OS. Additional software, specific to AI Accelerator installed as Docker container on top of the Compute module's host OS.

Installing the software

During installation and configuration the Compute module should remain connected to the internet. Installation and configuration of the software components of AI Accelerator should be performed in the following order:

1. Start the Compute module
2. Update AI Accelerator software
3. Configure the installation parameters
4. Uploads URCap files on to the robot
5. Re-start the robot's interface
6. Verify installation

Each step is described in more detail below.

**To start the
Compute
module**

1. Compute module comes with pre-installed software.
Login: `lab`
Password: `easybot`

CAUTION

Remember to change the password at first boot. Leaving the password unchanged will expose the compute module to significant cybersecurity risks.

**To get
software
update**

2. Universal Robots continuously working on improving AI Accelerator software. There might additional software functionality and bug fixes in updates posted to our web site.
Open <https://www.universal-robots.com/products/ur-developer-suite/ai-accelerator/> on Compute module.
Locate the AI Accelerator and follow instructions on the page on how to update the software.
The package contents will be installed in the `/home/lab/`

**To configure
installation
parameters**

3. Locate and edit the configuration file `ros/config/config.yaml` inside the home folder.
Following parameters are required:
 - Robot serial number (example `UR20235000000`)
 - Robot type and size (example `ur5e`)
Both are found on a sticker at the base of the robot arm
 - Host IP (this is the IP of the Compute module)
 Robot's serial number is used by ROS components to uniquely identify the robot.

**To configure
the robot**

4. Navigate to `/home/lab/pandai_ark/scripts` and run `./setupRobot.sh`
 - Enter robot's IP
 - Specify robot ssh password
 This script copies URCaps to robot, copies sample scripts, configures ROS broadcasting and installs custom ROS messages.
5. When the script finishes you must reboot the robot. Restarting the PolyScope X is not sufficient.

To verify installation

6. On the compute module open Terminal and navigate to `/home/lab/pandai_ark`

- Start the docker container by typing:

```
source ros/scripts/run_dev.sh
```

For off-line operation type:

```
source ros/scripts/run_dev.sh -b
```

This script finishes inside the Docker container, your default user is now `admin`

- As admin run the script:

```
./scripts/run_ark.sh
```

Running the script opens the **ARK Console UI** showing the camera view.

- Check the camera connection to the Compute module if the live view does not appear.

On the robot you can open the **AI Accelerator Dashboard** from **Applications** and verify that the camera view appears. Check that correct host IP is configured in the **AI Accelerator Dashboard**.

Troubleshooting

1. On the Tech Pendant tap the hamburger menu and tap back to URcap window.
2. Restart PolyScope X
3. Check the following settings:
 - ROS hardware permissions
 - Correct robot serial number
 - Correct host IP

If no camera view appears in URcaps running on the robot, check that `./scripts/run_ark.sh` is running on Compute module.

10.2. Camera Calibration

Description

The end effector and the camera must be calibrated for precise robot operation, allowing the system to accurately translate visual data into coordinated movements.

Calibration is performed by recording camera images and matching them with the robot poses. A special calibration board, with fixed positions, is used to recognize camera orientation.

The result of the calibration is the camera calibration file stored on the compute module (`ros/config/env.json`).

Repeating the calibration

It is necessary to perform the calibration again after making any changes that affect the position of the camera on the robot. These might be any adjustments to the camera mount, replacement of the gripper or tightening of the bolts that hold the camera on the tool flange.

Adjusting robot payload



CAUTION
 Ensure that you are using the correct Payload and Center of Gravity (CoG). Incorrect payload may result in Robot arm movement when pressing the Freedrive button.

You can use the Payload Estimation Wizard in PolyScope to assess the Payload and CoG.

Preparing for calibration

A calibration board is required to calibrate the camera. You can find and print a calibration board in the [calib.io](#) pattern generator. You can also adjust the grid and cell size in the **Calibration Studio** URCap. Make sure the printed board has the correct dimensions, as printer driver can introduce some scaling.

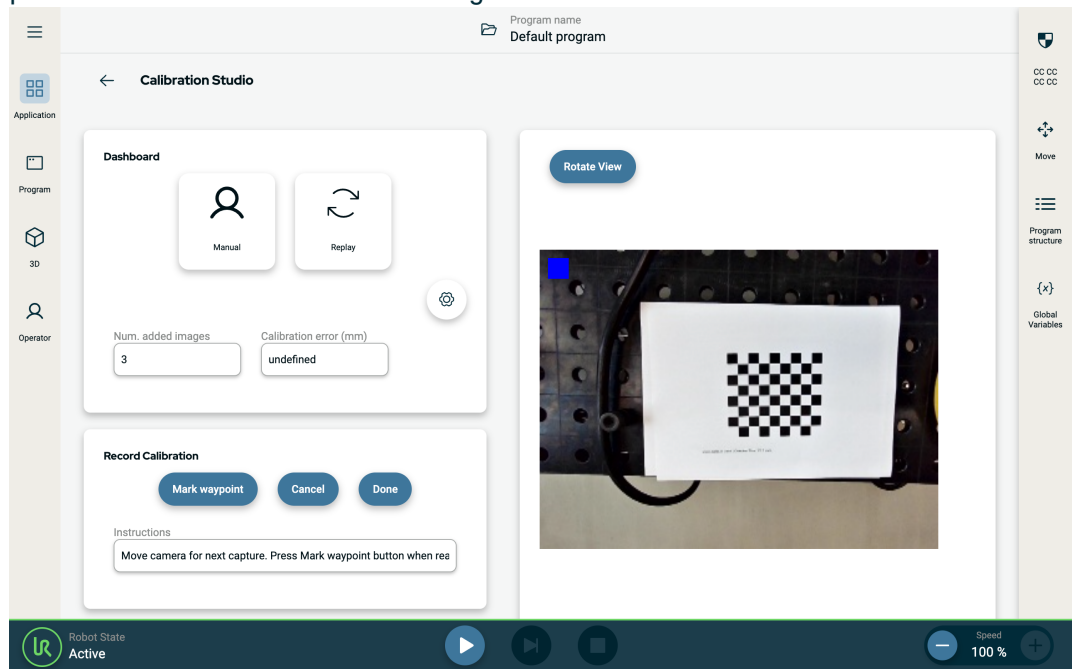

To set up your calibration board:

- Position the calibration board inside the robot reach area, where you can move the robot arm maintaining the distance of 20cm to 80 cm between the camera and the board.
- Do not make any adjustments to the position of the calibration board during the calibration.
- The Calibration board must be evenly lit. Avoid shadows, for example from robot arm or operators body.

You can improve calibration accuracy by tapping **Replay**. The robot automatically moves through all manually recorded poses and re-takes images of the calibration board.



WARNING
 Stand outside the robot reach, robot will move automatically.

To calibrate the camera

1. Launch the **Calibration Studio** URCap on the robot.
2. Tap the gear button and configure the Compute module IP address.
3. Tap **Apply**.
4. Tap **Manual** to start recording the calibration images.
5. Position the robot such way that calibration board is fully in camera view and there are some margins on all sides of the board. Tap **Mark waypoint**.
Calibration board does not have to be inside the region of interest (light blue rectangle).
6. Blue square flashes in top left corner of the live view.
7. If a red square flashes, the calibration board was not recognised.
8. You can also follow the calibration process in the terminal connected to the Compute module.
9. Record at least 12 images varying the robot poses, including the rotation of the tool flange. Tap **Done** after taking all images.
10. In the pop-up check the calibration results and press **Confirm**.

Finishing calibration

The calibration data is stored in: `ros/config/env.json`

Translation x,y,z are recorded in meters and should match camera offset from the robot's tool flange.

11. AprilTag

Description

AprilTags conceptually similar to QR codes, in that they encode data as two-dimensional grid of black and white squares. However, they differ in that the AprilTags not only carry data payload, but could be used for detecting tag position and orientation.

Implementaton

AI Accelerator software by default configured to use the 36h11 tag family in 30 mm size. Printable tags for the 36h11 family can be found at <https://docs.cbteeples.com/robot/april-tags>

Tag size can be configured in `ros/launch/ark_pipeline_full.py`

- Look for Apriltags node definition.
- Change size argument, default value is 'size': '0.03'. Size is specified in meters.
-

Demo

Tag recognition could be tested by opening the **ark_example_tags**.

Switch to tags view in Dashboard URCap and observe the camera view updating at intervals.

Tags can be configured for continuous detection by passing `apriltags_continuous:=true` as an argument to `ark_pipeline_full` in `ros/scripts/run_ark.sh`

The code for generating new families and instructions for using it can be found on github:

<https://github.com/AprilRobotics/apriltag-generation>

12. Demo: Object Classification

Description

A commonly utilized robot manufacturing process is in operation inspections. The robot uses a camera on the part it is inspecting.

Machine learning determines whether the part meets quality specifications. The camera is used to inspect parts for a single feature following a data capture and training.

This demo shows how to automate a quality inspection application.

The objective of this demo is to show a two-state classifier. There are only two possible outcomes of this recognition.

Step by step

1. Move the robot in to position from which the object recognition would eventually be performed.
2. Similar to the camera calibration, on the Compute module start the ROS environment `run_ark.sh`.
3. On the Compute module use the GUI.
The blue bounding box (configurable in `ros/config/config.yaml`) is the region of interest.
4. Start recording images for the `state_0`
5. Move the object you want to recognize within the bounding box of the camera view.
6. Take at least 20-30 images varying the object position and if desired, the object orientation.
Images are stored in `ros/data/datasets/classification_active/raw`
7. Record images of a second object, as the `state_1`
8. Click the **Train model**, this process can take several minutes.

You can follow the progress in the Terminal window on the compute module.

Training is complete when the message "onnx conversion completed" appears in Terminal and the model is written as a file in `ros/data/models/classification_active`

To use the model

1. Load the model.
2. In the UI, tap the **Load model**.
This loads the active model from `ros/data/models/calssification_active`
3. Tap **Classify** to test.
4. The Terminal window outputs the class (either `state_0` or `state_1`) and probability (recognition certainty).

Example of using recognition results**CAUTION**

A specific robot position stored in this program. Before executing this program check that robot can freely move to each of the stored waypoints and poses no risks.

1. Set program speed to 10%.
2. Select `wp_recognize` and tap **Move Here**.
3. Verify that there are no obstructions.
4. Repeat these steps for `state_0` and `state_1`.
5. If necessary, Freedrive robot to a new position and save it as `detect_wp`.

Included with AI Accelerator SDK you can find example of a robot program using the recognition results.

1. On the robot open `ark_example_classify` program, installed during setup.
2. Run the `run_ark.sh` on the compute module.
3. Load the classification model.
4. The robot program uses three waypoints `wp_recognize`, `state_0` and `state_1`.

Recognize waypoint is where camera looks at the object for recognition. Then we conditionally move robot to either `state_0` waypoint or `state_1` waypoint depending on the recognition results.

The value of variable `detected_class` is assigned by function `"ark_classification_retrieve()`. You can see details of ROS communication in URScript code.

13. Demo: Table Pick and Place

Description

A pick and place is a common task in manufacturing and production lines. In this demo the camera identifies objects and recognizes object bounding box. The robot's movements are planned accordingly.

The objective of this demo is to program robot to pick parts randomly placed on a table after preparing the training data and training.

This demo shows how to identify an object and determine its location and orientation.

Step by step

We first need to manually prepare training data, using approximately 60 images of an object. For each image, a bounding box of an object needs to be indicated. The images must then be split in to training and validation sets. The following steps are explained in subsequent sections:

- Capturing the images
- Preparing the training set
- Preparing the validation set
- Training the model
- Testing results

To capture the images

1. Record images using **AI Accelerator Dashboard**. Every time you tap **Save Image**, the current camera view is saved as PNG image in a folder `pandai_ark/ros/data/images` on Compute module.

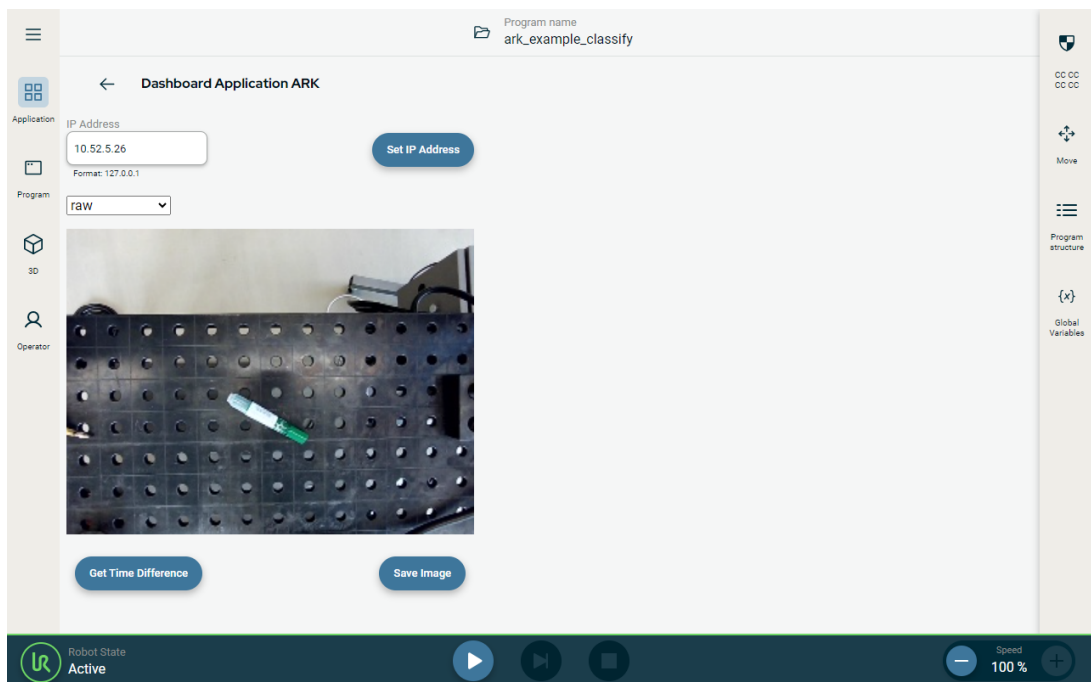

To prepare the training set

1. Open the web browser on the compute module and navigate to **MakeSense.ai**

This publicly available web site helps to label and annotate images.

2. Click **Get Started** and upload 80% of your images.
3. When the upload is complete, click **Object Detection**.
4. You need to specify labels for the objects you want to be recognized. Click the labels list and define at least one label.

Name the new label `object_1`.

You can define multiple labels and map multiple objects on a single image, as well as multiple instances of the same object.

5. Click **Start project**.
6. Specify a bounding box for each image.
Use the polygon tool and click points to map the bounding box.
7. Select object label for this new polygon.

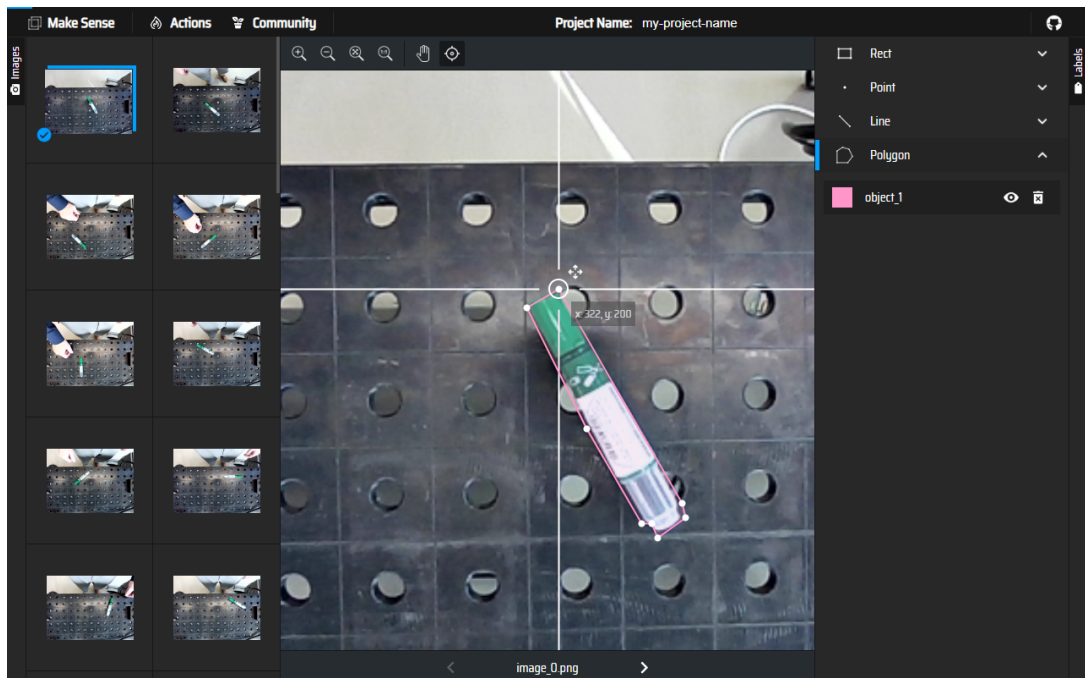

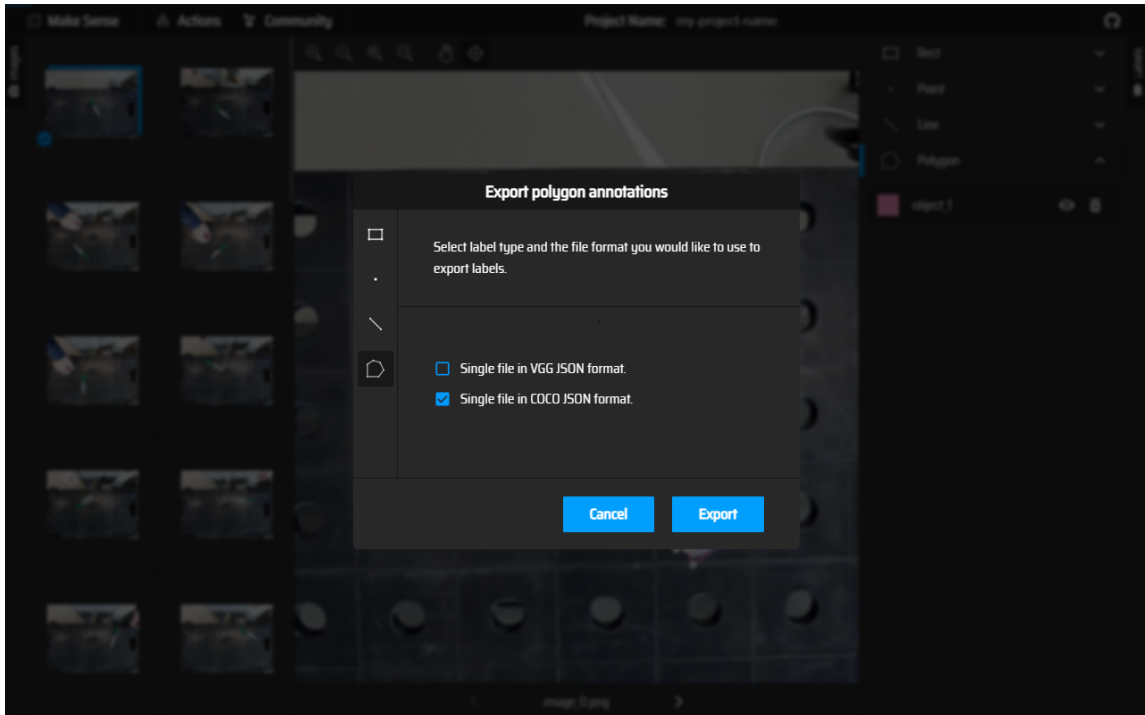

7. Once you annotate all the images in the training set, click **Actions and Export Annotations**.
8. Select **Single file in COCO JSON format** and click **Export**.
9. Save the exported file to `Downloads`.
10. Inside the `/ros/data/datasets` create folder `rt detr_active`
11. Inside create "train" folder and copy images of the training set and downloaded coco json file in here. Rename json file to `coco_train.json`

The training data consists of a combination of the JSON file and images.

To prepare the validation set

1. Repeat the above steps to create the validation set. Starting with uploading remaining 20% of the images to **MakeSense.ai**
2. Make sure to use the same label as in the training set.
3. Create folder `validation` inside the `rt detr_active`
4. Rename downloaded coco json file to `coco_validation.json` and copy it together with the images from validation set in to the validation folder.

To train the model

1. Train the model using GUI (you can restart it from `run_ark.sh`)
2. Use **Train model** in `rt detr_active` column of the GUI.

The training of the model can take anything from several minutes, depending on the total number of images and labeled objects in each image.

Testing the model

1. Run the `run_ark.sh` on the compute module.
2. Load the model in `rtdepr_active` column of the GUI.
3. Open **AI Accelerator Dashboard** on the robot.
4. Place an object within camera view.
5. Select **detection2d** view from the drop-down.
6. Tap **Detect** in the right column.
7. If an object is recognized a green bounding box will appear in camera view.

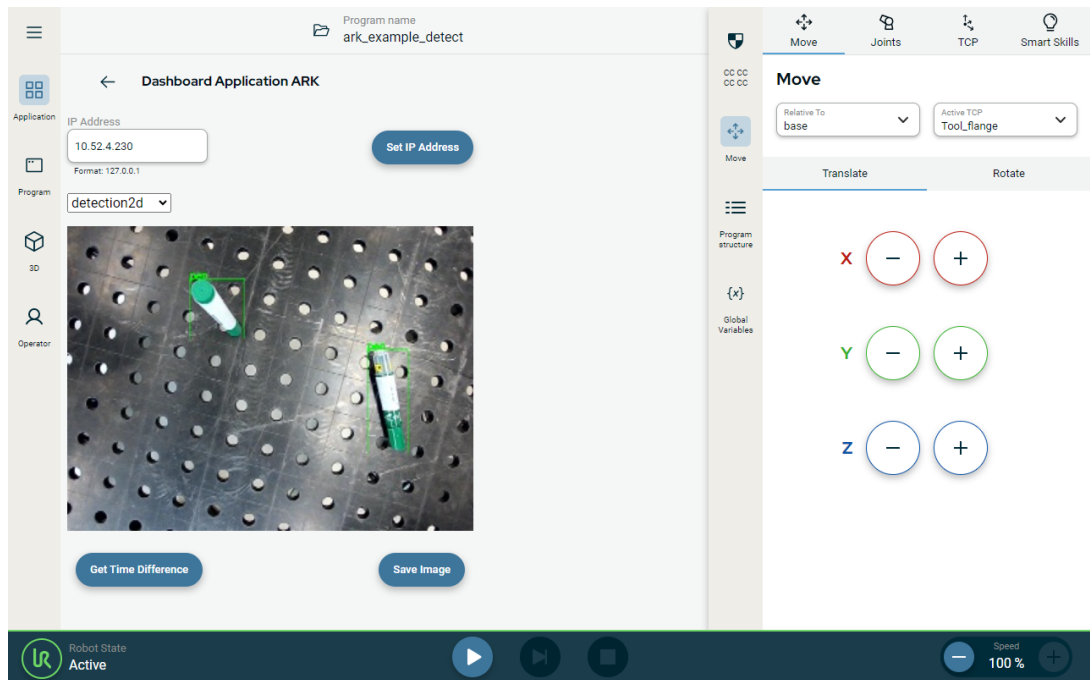

**Example of
using object
location****CAUTION**

A specific robot position stored in this program. Before executing this program check that robot can freely move to `detect_wp` and poses no risks.

1. Set program speed to 10%
2. Select `detect_wp` and tap **Move Here**
3. Verify that there are no obstructions
4. If necessary, Freedrive robot to a new position and save it as `detect_wp`

Included with AI Accelerator SDK you can find example of a robot program using the recognition results.

1. On the robot open `ark_example_detect` program, installed during setup.
2. Place objects within camera view.
3. Run the program.
4. Robot moves to waypoint `detect_wp` and captures an image.

The function `ark_detection_retrieve()` returns robot pose matching the bounding box of the recognized object.

5. If a pre-trained object is recognized, the robot will move to position 150 mm above an object. If multiple objects are recognized, robot will randomly choose one.

Software Name: PolyScope X
Software Version: 10.7
Document Version: 10.9.110