

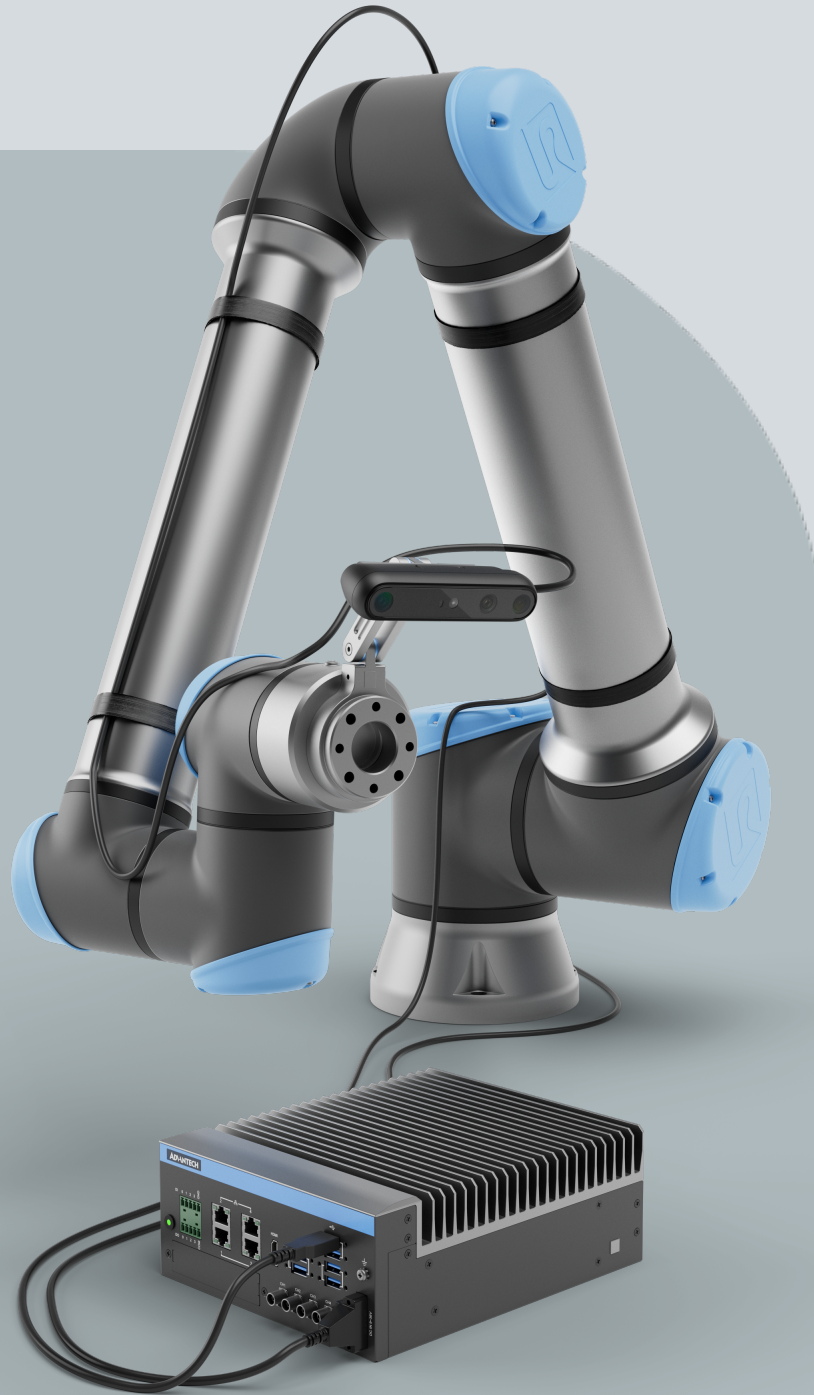

UNIVERSAL ROBOTS

User Manual

AI Accelerator





The information contained herein is the property of Universal Robots A/S and shall not be reproduced in whole or in part without prior written approval of Universal Robots A/S. The information herein is subject to change without notice and should not be construed as a commitment by Universal Robots A/S. This document is periodically reviewed and revised.

Universal Robots A/S assumes no responsibility for any errors or omissions in this document.

Copyright © 2009-2025 by Universal Robots A/S.

The Universal Robots logo is a registered trademark of Universal Robots A/S.



Contents

1. Introduction	8
1.1. About This Guide	8
1.2. Product Description	9
2. Safety	10
2.1. Safety Message Types	11
2.2. Validity and Responsibility	12
2.3. Limitation of Liability	12
2.4. General Warnings and Cautions	12
2.5. AI AcceleratorSafety	14
3. Intended Use	16
4. Operating Environment	19
5. Declarations and Certificates (original EN)	20
6. Technical Specifications	21
7. Assembling the AI Accelerator	22
7.1. Camera	22
7.2. Attaching the Camera Mount	23
7.3. Camera cable	26
7.4. Compute Module	30
7.5. Tool Selection	30
8. Connectivity	32
9. Cybersecurity Threat Assessment	33
9.1. General Cybersecurity	33
10. Software	34
10.1. Installing the software	35
10.2. Using the AI Accelerator software	35
10.3. Camera calibration	38
11. Copyright and Disclaimers	40

1. Introduction

1.1. About This Guide

Description This guide provides the essential information to start using the AI Accelerator.

Terminology This document uses terminology from industrial robotics and AI research.

- Tool refers to the end effector, such as a gripper.
- Part refers to the workpiece.
- Experiments are the trial exercises in this guide.

Assembling the AI Accelerator can require supervision by technically trained personnel.

In the box AI Accelerator ships in a single box with the following parts:

- Compute module from Advantech, based on NVIDIA Jetson Orin
- Camera
- Camera mount
- Camera cable
- Cable straps for camera cable (4 pcs)
- Tool flange bolts (4 pcs, 40 mm)
- Calibration board
- This document

The following parts are required to complete the demo setup described in [10 Software on page 34](#):

- Universal Robots e-Series or UR-series robot (purchased separately)
-

Business contact details Universal Robots A/S (hereinafter Universal Robots or UR)
Energivej 51, 5260 Odense S, Denmark
+45 89 93 89 89
<https://www.universal-robots.com>

1.2. Product Description

Description AI Accelerator enables PolyScope X integration with Perception and AI.

The AI Accelerator extends Universal Robots capabilities with:

- Hardware and software for camera-based AI applications
- Computational power optimized for AI applications
- A URCap framework for distributing and using AI applications

Scripts and example applications are available from <https://docs.universal-robots.com/>.

2. Safety

Description

This chapter contains important safety information that you must read and understand **before** first use of the AI Accelerator.

Read the general safety information and the instructions and guidance pertaining to the risk assessment and intended use provided. Pay particular attention to text accompanied by warning symbols. Read and understand the specific engineering data relevant to mounting and installation to understand the integration of UR robots before the robot is powered on for the first time.

The integration and application of AI Accelerator require risk assessment and risk reduction, even if the application remains undeployed.

- Always conduct a thorough risk assessment specific to your experiment and subsequent application.
- Reduce risks in accordance with the results of the risk assessment.



NOTICE

Universal Robots disclaims any and all liability if any part of the AI Accelerator is damaged, changed, or modified in any way. Universal Robots cannot be held responsible for any damages caused to any equipment due to programming errors or malfunctioning of the components.



READ MANUAL

Read the manual for the robot **before** first use. Follow all safety precautions stated in the robot manual.

2.1. Safety Message Types

Description

Safety messages are used to emphasize important information. Read all the messages to help ensure safety and to prevent injury to personnel and product damage.



WARNING

Indicates a hazardous situation that, if not avoided, can result in death or serious injury.



WARNING: ELECTRICITY

Indicates a hazardous electrical situation that, if not avoided, can result in death or serious injury.



WARNING: HOT SURFACE

Indicates a hazardous hot surface where injury can result from contact and non-contact proximity.



CAUTION

Indicates a hazardous situation that, if not avoided, can result in injury.



GROUND

Indicates grounding.



PROTECTIVE GROUND

Indicates protective grounding.



NOTICE

Indicates the risk of damage to equipment and/or information to be noted.



READ MANUAL

Indicates more detailed information that should be consulted in the manual.

2.2. Validity and Responsibility

Description The information in this manual does not cover designing, installing, integrating, or operating a robot application, nor does it cover all peripheral equipment that can influence the safety of the robot application.

The robot application must be designed and installed in accordance with the safety requirements set forth in the relevant standards and regulations of the country where the robot is installed.

The person/s integrating the AI Accelerator are responsible for ensuring the applicable regulations in the country concerned are observed and that any risks in the robot application are adequately reduced. This includes, but is not limited to:

- Performing a risk assessment for the complete robot system
 - Interfacing other machines and additional safeguarding if required by the risk assessment
 - Setting the correct safety settings in the software
 - Ensuring safety measures are not modified
 - Validating that the robot application is designed, installed, and integrated
 - Specifying instructions for use
 - Marking the robot installation with relevant signs and contact information of the integrator
 - Retaining all documentation, including the application risk assessment, this manual, the robot manual, and additional relevant documentation.
-

2.3. Limitation of Liability

Description Any information provided in this manual must not be construed as a warranty, by UR, that the industrial robot will not cause injury or damage, even if the industrial robot complies with all safety instructions and information for use.

2.4. General Warnings and Cautions

Description The following warning messages can be repeated, explained, or detailed in subsequent sections.

**WARNING**

Failure to adhere to the general safety practices listed below can result in injury or death.

- Verify the robot arm, camera mount, and tool/end effector are properly and securely bolted in place.
- Verify the robot application has ample space to operate freely.
- Verify personnel are protected during the lifetime of the robot application including transport, installation, commissioning, programming/ teaching, operation and use, dismantling and disposing.
- Verify robot safety configuration parameters are set to protect personnel, including those who may be within reach of the robot application.
- Avoid using AI Accelerator if any of its parts are damaged.
- Avoid wearing loose clothing or jewelry when working with the robot. Tie back long hair.
- Avoid placing any fingers behind the internal cover of the Control Box.
- Inform users of any hazardous situations and the protection that is provided, explain any limitations of the protection and the residual risks.
- Inform users of the location of the emergency stop button(s) and how to activate the emergency stop in case of an emergency or an abnormal situation.
- Warn people to keep outside the reach of the robot, including when the robot application is temporarily inactive (waiting).
- Be aware of robot orientation to understand the direction of movement when using the Teach Pendant.
- Adhere to the requirements and guidance in ISO 10218-2.

**WARNING**

Handling tools/end effectors with sharp edges and/or pinch points can result in injury.

- Make sure tools/end effectors have no sharp edges or pinch points.
- Protective gloves and/or safety glasses can be required.

WARNING: HOT SURFACE

Prolonged contact with heat generated by the robot arm, Compute module, or the Control Box during operation can cause injury.

- Do not handle or touch the robot while in operation or immediately after operation.
- Check the temperature on the log screen before handling or touching the robot.
- Allow the robot to cool down by powering it off and waiting one hour.

CAUTION

Failure to perform a risk assessment prior to integration and operation can increase the risk of injury.

- Perform a risk assessment and reduce risks prior to operation.
- If determined by the risk assessment, do not enter the range of the robot movement or touch the robot application during operation. Install safeguarding.
- Read the risk assessment information.

CAUTION

Using the robot with untested external machinery or in an untested application can increase the risk of injury to personnel.

- Test all functions and the robot program separately.
- Read the commissioning information.

NOTICE

Very strong magnetic fields can damage the robot.

- Do not expose the robot to permanent magnetic fields.

READ MANUAL

Verify all mechanical and electrical equipment is installed according to the specifications and warnings found in the **Mechanical Interface** and in the **Electrical Interface** sections of the robot User Manual.

2.5. AI Accelerator Safety

AI Accelerator The AI Accelerator enables AI to work with vision and sensor feedback to make logical decisions about the robot arm's behavior.

**WARNING**

AI decision-making can introduce additional risks, including unintended motion, safety hazards, and system failures.

- Be aware of sudden, unexpected motions resulting from AI decisions.
- Be aware of the risk of unpredictable motion patterns.
- Restrict personnel traffic within and around the robot application's reach when the application runs an AI experiment or demo.

**WARNING**

Prolonged robot inactivity can be misinterpreted as a stop, which can result in equipment damage or personnel injury due to unexpected movement or a sudden start.

- The application developer is responsible for installing and programming AI Accelerator to reduce unexpected movement situations.
- Check the program state to determine if the robot is completely stopped or temporarily inactive (waiting). If the program is running but the robot is not moving, the robot can move again unexpectedly.

**WARNING**

Failure to turn off, secure, and lock out all sources of hazardous energy to the robot application when servicing or repairing any part of the AI Accelerator setup can result in death or serious injury due to unexpected movement.

- Turn off, secure, and lock out sources of hazardous energy before conducting all service and repair procedures.

3. Intended Use

Description

The AI Accelerator is intended to create robot applications using Perception, AI and PolyScope X integraton solution.

Possible applications of AI Accelerator are limited by combination of the technical specifications of it's components. Consult technical specification of individual components to determine their suitability for a purpose.

For details about the conditions under which the robot should operate, see Declarations and Certificates and the technical specifications in the robot **User Manual**.

All UR robots are equipped with safety functions, which are purposely designed to enable collaborative applications, where the robot application operates together with a human. The safety function settings must be set to the appropriate values as determined by the robot application risk assessment.

Collaborative applications, without guards or protective devices, are only intended for non-hazardous applications, where the complete application, including tool/end effector, work piece, obstacles and other machines, is low risk according to the risk assessment of the specific application.



WARNING

The AI Accelerator shall not be used with CB3 robots or PolyScope versions prior to 10.11.1.

- Only use AI Accelerator with UR e-Series robots running PolyScope X 10.11.1 or later.

**WARNING**

Using UR robots or UR products outside of the intended uses can result in injuries, death and/or property damage. Do not use the UR robot or products for any of the below unintended uses and applications:

- Medical use, i.e. uses relating to disease, injury or disability in humans including the following purposes:
 - Rehabilitation
 - Assessment
 - Compensation or alleviation
 - Diagnostic
 - Treatment
 - Surgical
 - Healthcare
 - Prosthetics and other aids for the physically impaired
 - Any use in proximity to patient/s
- Handling, lifting, or transporting people
- Any application requiring compliance with specific hygienic and/or sanitation standards, such as proximity or direct contact with food, beverage, pharmaceutical, and /or cosmetic products.
 - UR joint grease can be released into the air (vapor), or drip.
- Any use, or any application, deviating from the intended use, specifications, and certifications of UR robots or UR products.
- Misuse is prohibited as the result could be death, personal injury, and /or property damage

UNIVERSAL ROBOTS EXPRESSLY DISCLAIMS ANY EXPRESS OR IMPLIED WARRANTY OF FITNESS FOR ANY PARTICULAR USE.

**WARNING**

- The AI Accelerator is designed for use in standard industrial environments and is sold “AS-IS”. Universal Robots makes no declaration of conformity, claim of functionality, or fitness for particular purpose to the extent the AI Accelerator is used beyond the prescribed intended use.
- The user shall ensure that the AI Accelerator is at all times used in full compliance with all applicable regulatory and legal requirements. If the user utilizes the AI Accelerator for applications outside the intended use, the user shall bear sole and exclusive liability.

**READ MANUAL**

Failure to use the AI Accelerator in accordance with the intended use can result in unsafe situations.

- Read and follow the recommendations for intended use provided in this manual.



4. Operating Environment

Description Special precautions should be taken when using components of the AI Accelerator in industrial environment.

Consider summary of the factors, such as ingress prevention rating for each of the components, the airflow requirements and ambient temperature range. See [6 Technical Specifications on page 21](#) and **Technical Specifications** section in Robot User Manual.



WARNING: ELECTRICITY

Failure to follow any of the below can result in serious injury or death due to electrical hazards.

- Make sure all equipment not rated for water exposure remain dry. If water is allowed to enter the product, lockout-tagout all power and then contact your local Universal Robots service provider for assistance.

6. Technical Specifications

Package dimensions	350 x 300 x 260 mm
Package weight	5 kg
Compute module	NVIDIA Jetson Orin Advantech MIC-733-AO 64Gb, 1Tb SSD
Compute module IP classification	IP40
Compute module operating temperature	-10 ~ +60 °C with 0.7 m/s airflow (MaxN mode)
Compute module operating humidity	95% @ 40 °C (non-condensing)
Camera	Orbbec Gemini 335Lg
Camera IP classification	IP67
Camera mount	Tool flange extender and camera bracket
Camera mount weight	300 gr
Camera mount material	Aluminium
Camera cable	Amphenol RF 5 m.
Cable guides material	Velcro® polypropylene and velour PA
Calibration board	8x7 nodes, 15 mm checker size

7. Assembling the AI Accelerator

Description	Complete assembly of AI Accelerator requires the following steps: <ol style="list-style-type: none"> 1. Mounting the robot 2. Attaching camera mount and optionally an end effector (See Attaching the Camera Mount) 3. Affixing camera cable (See Camera cable) 4. Connecting Ethernet cables 5. Connecting power cables
--------------------	---

Mounting the robot	For mechanical and electrical installation instructions of the robot arm and the Control Box, refer to the robot User Manual .
---------------------------	---

7.1. Camera

Description	The main options for camera mounting in the robot machine vision application are: robot-mounted or fixed-mounted. The camera mount included in AI Accelerator allows camera to be mounted on Universal Robots robot arms.
--------------------	---

Camera mount	The AI Accelerator camera mount is designed to be inserted between the robot tool output flange and the end effector. Before mounting the camera, familiarize yourself with the Securing Tool section of the Mechanical Interface chapter in the robot User Manual and mounting instructions that came with the selected end effector.
---------------------	---

Assembly

The camera mount is supplied pre-assembled. To attach camera to the mount:

1. Remove camera from the packaging.
2. Point the connector on the camera towards the tool flange adapter.
3. Use two M4 screws to attach camera to the holder.
4. Align camera cable along the grooves on the camera holder and attach it with wire ties.

**Camera Cable**

Chapter [Camera cable](#) explains how to arrange the cable connecting the camera to compute module, externally along the robot arm.

7.2. Attaching the Camera Mount

Securing the Robot Arm

Read the **Mechanical Interface** section in robot User Manual.

Before attaching the camera you should mount the robot arm according to the requirements specific to your robot model as described in **Securing the Robot Arm** chapter in robot User Manual. You can test the robot movement without any attachments.

**End of
Arm**

Read the **Securing Tool** chapter in robot User Manual.

Supplied with the kit you will find four M6 bolts. Bolts in the kit are suitable for attaching the camera mount without an end effector.

Camera mount could be inserted between the robot tool flange connector and an end effector using longer bolts.

**CAUTION**

Very long M6 bolts can press against the bottom of the tool flange and short circuit the robot.

- Do not use bolts that extend beyond 10 mm to mount the tool.

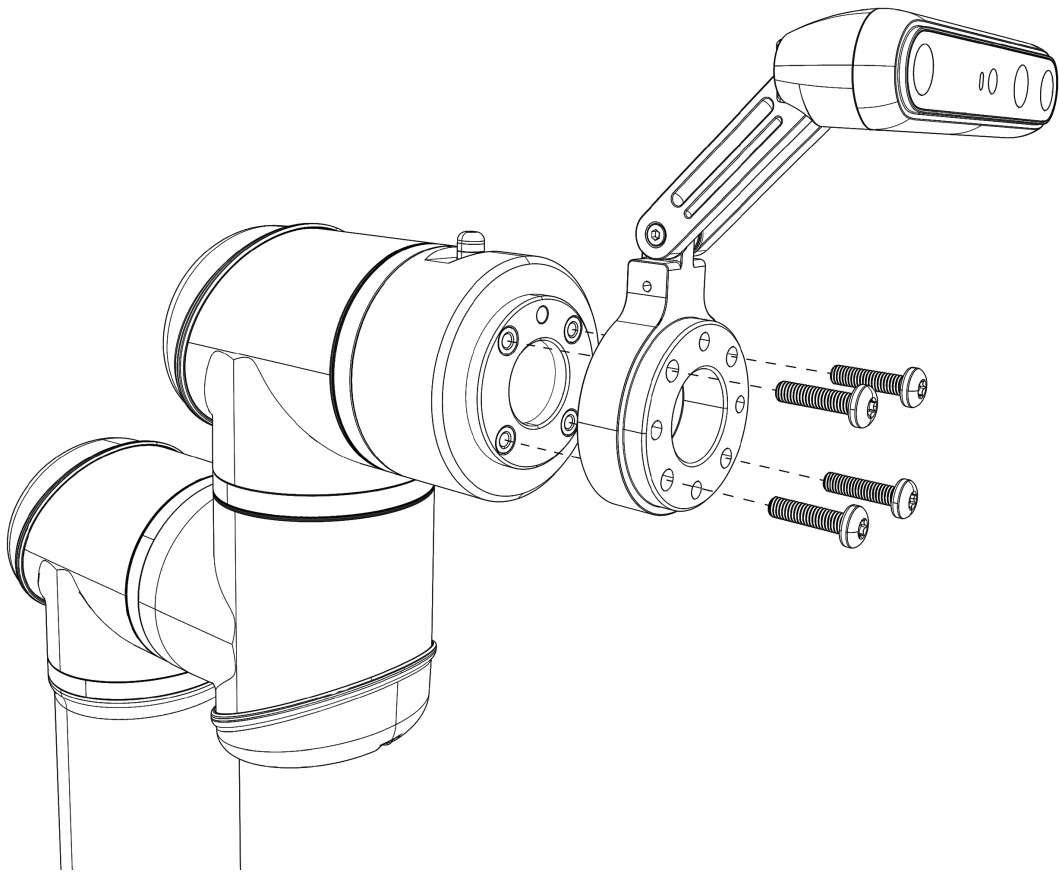

Correct payload**CAUTION**

Incorrect payload can result in unexpected robot movement when entering Freedrive.

- Remember to set the correct payload on the robot and adjust the Center of Gravity (CoG).

As a guidance, assembled camera mount, camera and mounting bolts weight approximately 480 gr.

Initialize**Arm - LOCKED** 

The robot arm is powered but for safety has its brakes applied.

Confirm that the below payload is accurate before unlocking.

Active Payload
0.480 kg



Application Payload | 0 kg

 Power Off

 Unlock



Robot State
Locked

Adjusting the camera mount

Robot vision applications require consistent camera positioning, either fixed to the robot arm or static relative to the robot base.

To ensure the necessary rigidity, camera mount parts are secured with locking pins, which prevent accidental changes to the camera position. Adjusting the camera position requires disassembling the camera mount, realigning the parts, and reassembling them.

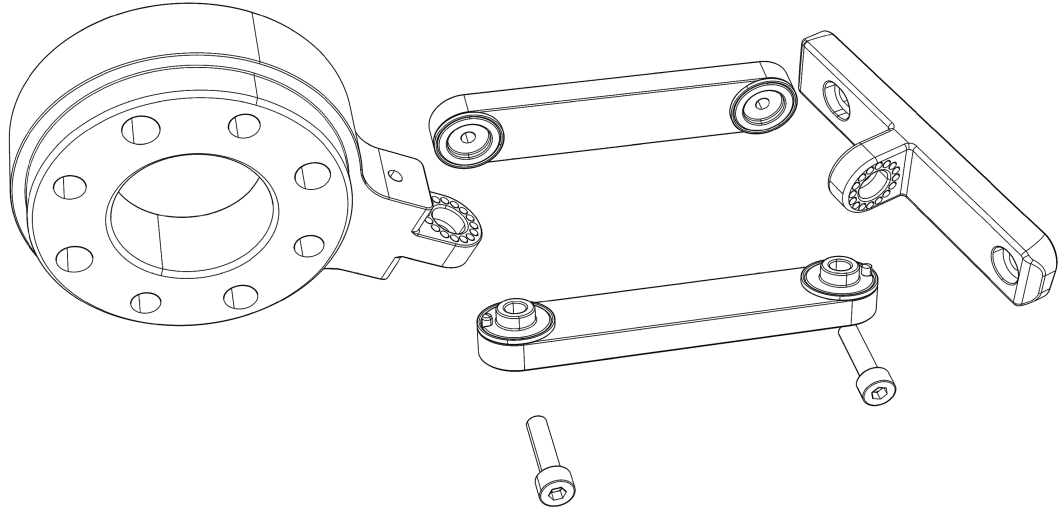
**CAUTION**

- Do not attempt to adjust camera position by forcing camera mount parts.
- Camera mount screws should be tightened to 5 Nm. Do not overtighten these screws.

**CAUTION**

Repeat camera calibration after adjusting camera position.
See [10.3 Camera calibration on page 38](#).

7.3. Camera cable

Description**CAUTION**

Your robot should be mounted and powered off before attaching the external cable and end effector.

External cables can create risks of entanglement for the operator or interfere with robot operation.

Cables can be damaged by the robot motion and create additional hazards.

Care must be taken when affixing external cables that these risks are mitigated.

- Restrict range of possible joint movement to prevent damage to the camera cable.

To affix the camera cable

While robot joints can rotate plus and minus 360 degrees from the zero position, this movement will damage the camera cable and in practice is not required in most applications.

The safety functions of the robot can be used to limit the motions range of the joint. Refer to the robot **User Manual** for descriptions of how to use the safety functions.

1. Before affixing the cable, pose the robot to the median position of all movements necessary for your application.
2. Attach the camera cable to the camera.
3. Make loose coil around wrist joints of the robot arm. Run the remainder of the cable along the arm.
4. Use cable straps to fix cable to the upper part of the arm. Make sure that the cable is not under the buckles of the cable straps.
5. Leave some loose cable between the two tubes of the robot arm and fix the cable to the bottom part of the arm.
6. Connect the camera cable to compute module.

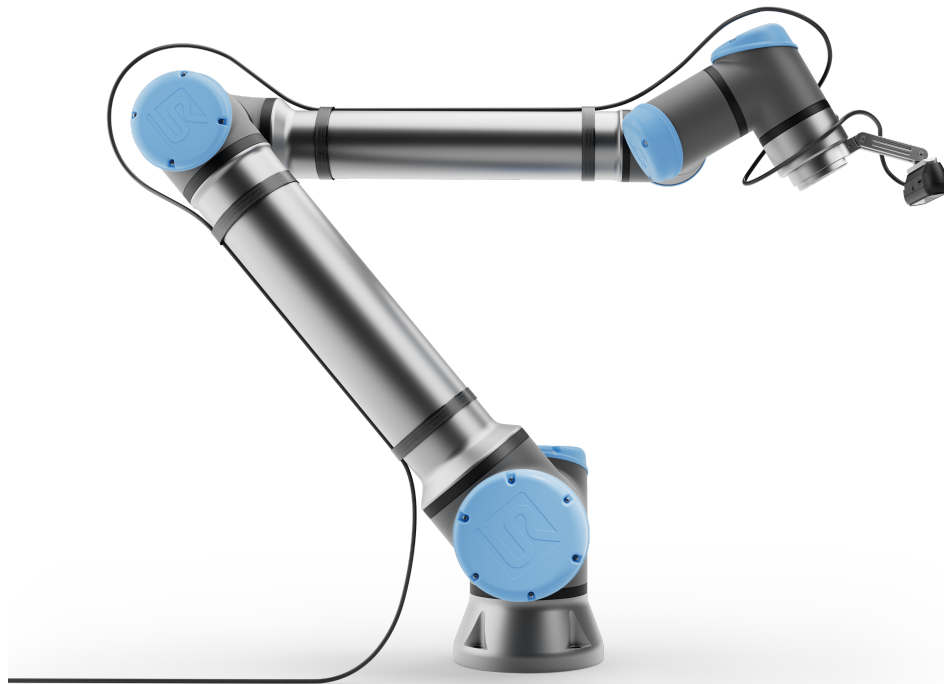

Restricting joint movement

When the camera cable is attached to the robot, you can restrict joint movement. Before continuing you should familiarize yourself with robot **Freedrive**, refer to the robot User Manual.

To restrict joints movement:

1. In PolyScope open 3D View and **Joints** tab.
2. Start the robot arm, unlock the brakes and start Freedrive.
You may want to move the Freedrive restrictions panel to make joint angles visible.
3. While in Freedrive, slowly move robot arm from side to side, imitating robot movement in your application.
4. Observe the camera cable and give cable more slack or reposition cable coils if necessary.
5. Move robot to most extreme positions of your application and take note of the joint angles for each joint.
6. Enter these values as **Joint Positions** in **Joint Limits** of the **Safety** settings of your robot.

Read robot User Manual, **Safety** section on how to enter joint restrictions in PolyScope X.

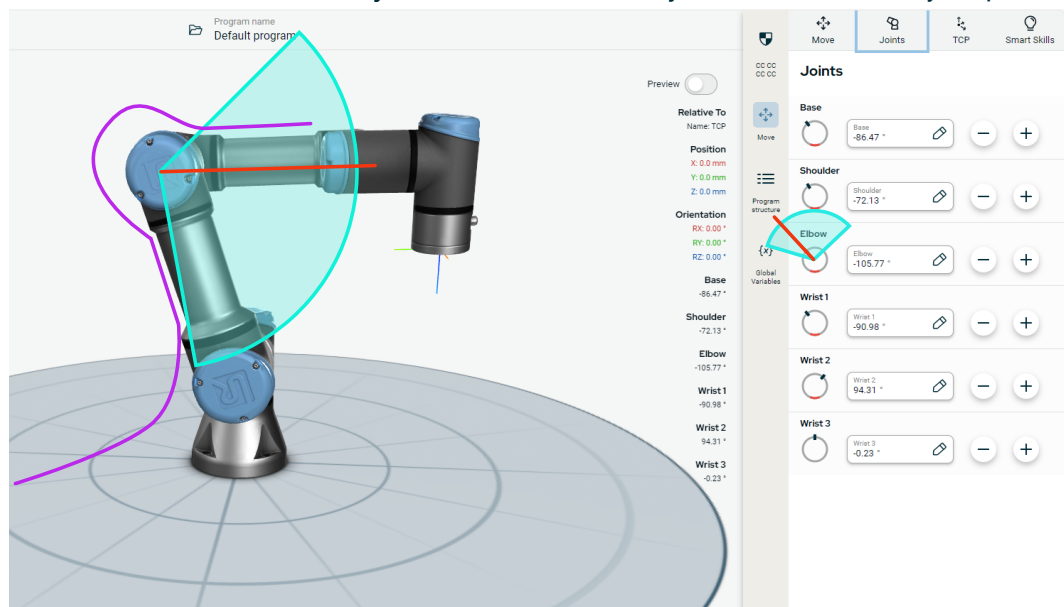

Testing joint limits

Try to move robot using the **Move** tab and verify that camera cable is not overtightened or clamped by possible robot movements.

7.4. Compute Module

Description AI Accelerator includes Compute module based on NVIDIA Jetson Orin.



READ MANUAL

Read the NVIDIA Jetson Orin manual and follow all safety instructions.

Compute Module position

When positioning the Compute Module, ensure the following:

- The Compute Module is placed in a clean and dry space with sufficient airflow.
- The cable from the 3D camera can reach the Compute Module.

Connecting Compute Module

The Compute Module network connections are pre-configured with Lan1 designated for connecting to the robot's Control Box and Lan2 available for optional Internet connection.

Connect the port marked Lan1 on the Compute Module directly to the robot's Control Box with an Ethernet cable. Do not use router or switch.



Copyright © 2009-2025 by Universal Robots A/S. All rights reserved.

7.5. Tool Selection

Description The AI Accelerator does not provide a tool or end effector. You need to choose the correct end effector for your set up/work cell. Tool choice can depend on different requirements including:

- Purpose
- Weight
- Connections

Purpose A gripper type end effector, like a vacuum or finger gripper, is the most common tool for moving objects around. Verify this gripper works with Universal Robots software PolyScope X.

Weight The total weight of the camera module, gripper and work part shall not exceed the maximum payload of your robot.

Connections The selected end effector should use tool flange output for communicating with the robot. Running an additional external cable or pneumatic pipe for a vacuum gripper can complicate your application.

Make sure your selected end effector does not obscure camera vision.
You can rotate camera around tool flange adapter if necessary.

**CAUTION**

Remember to adjust payload and TCP settings after change of tooling.

8. Connectivity

Description This section describes the connection of the components of the AI Accelerator



WARNING: ELECTRICITY

Do not use any cables if they are damaged or show signs of wear.

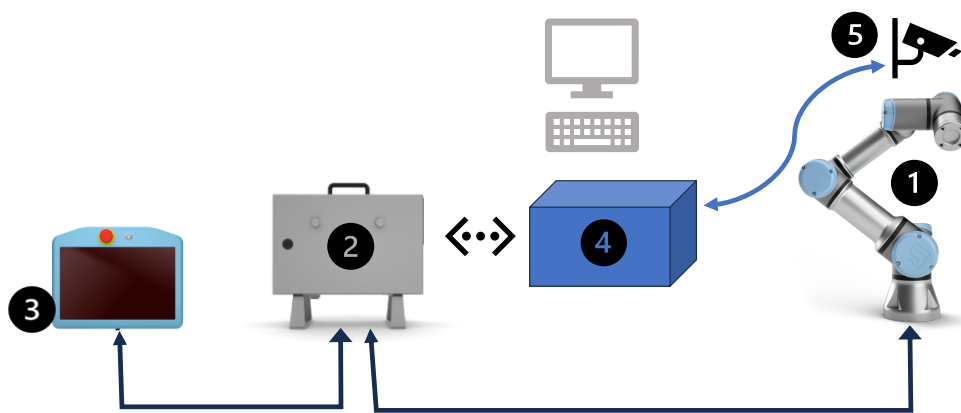

1. **Robot Arm**
Connected to Control Box with proprietary cable.
2. **Control Box**
Connected to the mains power (not shown).
3. **Teach Pendant**
Connected to the Control Box with proprietary cable.
4. **Compute module**
Directly connected from Lan1 on the compute module to Control Box via Ethernet cable.
5. **Camera**
Connected to Compute module with supplied camera cable (USB or GMSL).

9. Cybersecurity Threat Assessment

9.1. General Cybersecurity

Description

Connecting components of AI Accelerator to a network can introduce cybersecurity risks. These risks can be mitigated by using qualified personnel and implementing specific measures for protecting the robot's cybersecurity.

Implementing cybersecurity measures requires conducting a cybersecurity threat assessment.

The purpose is to:

- Identify threats
- Define trust zones and conduits
- Specify the requirements of each component in the application



WARNING

Failure to conduct a cybersecurity risk assessment can place the robot at risk.

- The integrator or competent, qualified personnel shall conduct a cybersecurity risk assessment.



NOTICE

Only competent, qualified personnel shall be responsible for determining the need for specific cybersecurity measures and for providing the required cybersecurity measures.



READ MANUAL

Read the robot User Manual sections **Cybersecurity Requirements** and **Cybersecurity Hardening Guidelines**.

10. Software

Description

AI Accelerator uses ROS messaging for two-way communication between the Docker software run by the Compute module and the URCap running in robot's controller.

Before running the software installation and configuration scripts, make sure all hardware is correctly connected.

1. Robot's control box and Compute module must be directly connected.
2. Camera cable is plugged in to Compute module.
3. Robot's control box is powered on and PolyScope X started.

The brakes in the robot arm can remain engaged until you proceed to calibration or other activities requiring robot movement.

Correct time settings

Time synchronization and time stamp is extensively used by components of AI Accelerator. Therefore it is important to set correct time in robot's controller and compute module.

Correct network settings

The AI Accelerator must be on the same network as the robot's Control Box.

1. Open the hamburger menu in the top left corner and select **Settings**
2. Navigate to the network menu and unlock if necessary
3. Change to static IP, IP `192.168.0.10`, Subnet mask `255.255.255.0`
4. Tap **Apply Configuration**
5. Navigate to the **Services** menu and unlock if necessary
6. Enable ROS2 and set the `ROS_DOMAIN_ID` to `1`
7. Tap **Lock and Close**

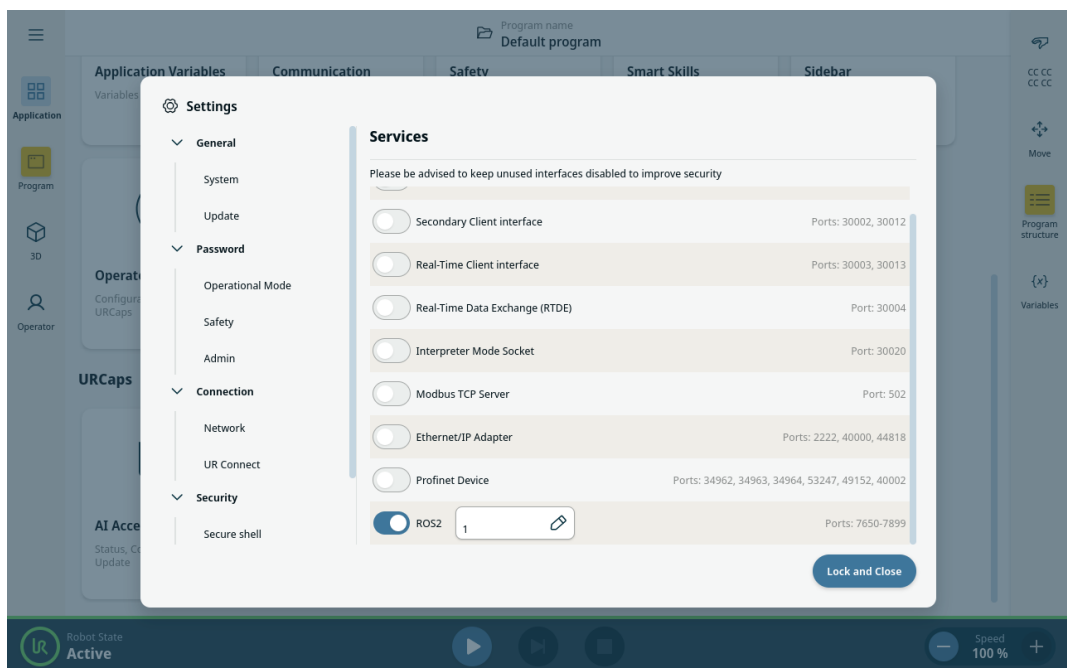

10.1. Installing the software

Description The compute module of the AI Accelerator comes with pre-installed OS. The remaining software is installed on the robot via URCaps.

Installing the URCaps Installation and configuration of the software components of AI Accelerator should be performed in the following order:

1. Download URCaps from Centercode and save them on a USB drive
2. Start the Compute module and the robot
3. Install the URCaps

Each step is described in more detail below.



CAUTION

PolyScope X on the robot needs to be the latest version

Download URCaps

1. Open <https://www.universal-robots.com/products/ur-developer-suite/ai-accelerator/>. Universal Robots continuously work on improving AI Accelerator software. There might additional software functionality posted to our web site.
2. Locate the AI Accelerator and follow instructions on the page.
3. Download `aia-core-<version>.urcapx` and `orbbec-gemini-v335Lg-<version>.urcapx` from centercode.
4. Save both files on a USB drive.

Start system

1. Turn on the compute module. It will auto start when power is connected.
2. Turn on the robot by pressing the power button on the Teach Pendant.

Install URCaps

1. Insert USB drive in the Teach Pendant or Control Box (recommended)
 2. Tap the folder icon at the top of the screen to enter System Manager
 3. Navigate to the URCap section and unlock it if necessary
 4. Tap the +URCap button and follow the instructions to install the URCaps
-

10.2. Using the AI Accelerator software

Description The AI Accelerator comes with a software to setup and monitor the system. The software is installed as a URCap (aia-core) and can be found in PolyScope X **Application** settings.

Adding a camera

Installation and configuration of the software components of AI Accelerator on the robot should be performed in the following order:

1. Open AI Accelerator URCap and navigate to the **Camera Configuration** section. This shows a list of currently available cameras.
2. Tap the **Add camera** button to add a camera.
3. Select the camera type from the list. More camera types can be added via URCaps. Universal Robots provides URCap for the Orbbec camera.
4. The camera is now added and you should see the live feed from the camera.

You can remove the camera or calibrate it by tapping the buttons under the camera name.

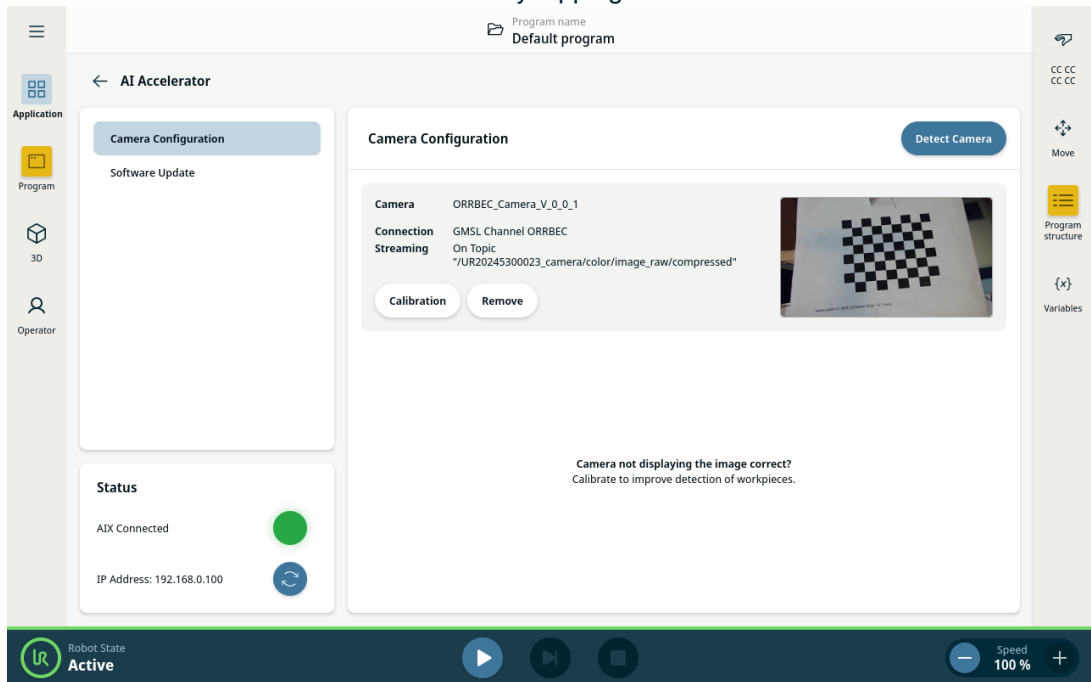

In the bottom left corner you can see the status and IP address of the compute module.

Updating software

1. Navigate to the **Software Update** section. This shows the current versions of URCaps.
2. Insert a USB drive with the new version of AI Accelerator software. For best performance you should use USB port inside the Control Box, not the USB port on the Teach Pendant.

You can find the latest update on Centercode

3. Tap the **Check for updates** button and choose the .aiup file
4. Wait for the update to complete. This may take a while and AI Accelerator may need to restart more than once.
5. Navigate to the **Software Update** section to verify that the update was successful.

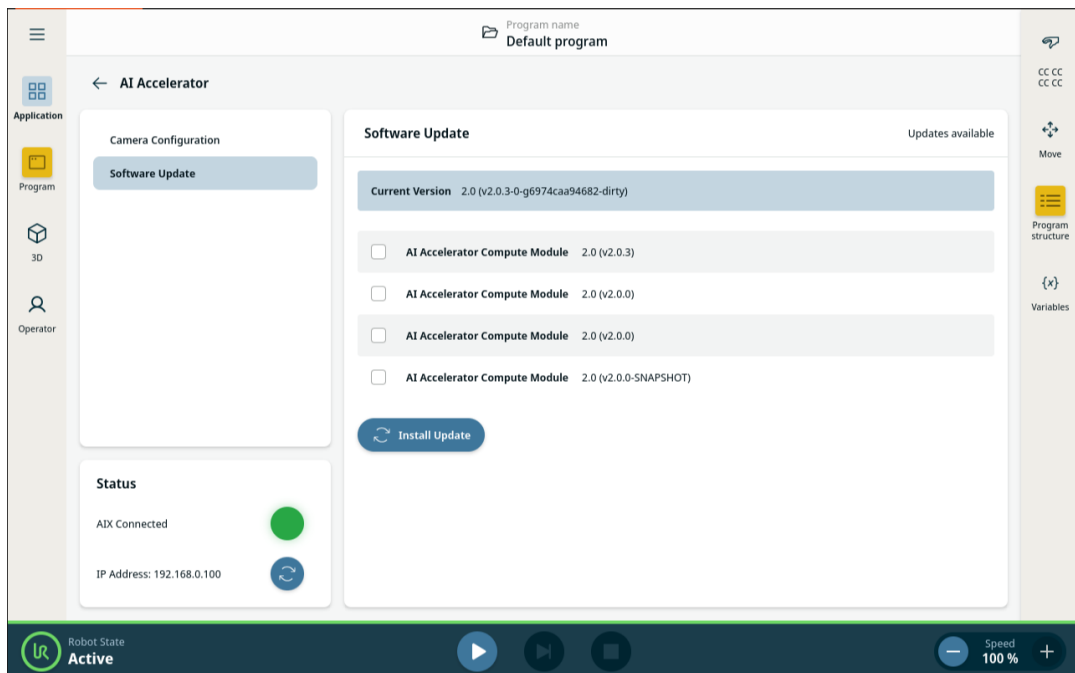

WARNING

All data on the compute module will be lost after the update. Make sure everything is backed up before updating.

Trouble shooting

I can't see the live camera feed:

- Check that the IP address on the robot is set correctly
- Check that the cables are correctly connected
- Check that ROS2 is enabled and domain id set to 1
- Check that correct camera URCap is installed
- Check that the physical selector switch on the camera is set to the cable type you are using
- Restart PolyScope X

10.3. Camera calibration

Description The end effector and the camera must be calibrated for precise robot operation, allowing the system to accurately translate visual data into coordinated movements.

Calibration is performed by recording camera images and matching them with the robot poses. A special calibration board, with fixed positions, is used to recognize camera orientation.

Adjusting robot payload



CAUTION

Ensure that you are using the correct Payload and Center of Gravity (CoG). Incorrect payload may result in Robot arm movement when pressing the Freedrive button.

You can use the Payload Estimation Wizard in PolyScope to assess the Payload and CoG.

Preparing for calibration

A calibration board is required to calibrate the camera and is provided with the AI Accelerator. It is also possible to use a custom calibration board.

- Position the calibration board inside the robot reach area, where you can move the robot arm maintaining the distance of 20 to 80 cm between the camera and the board.
 - Do not make any adjustments to the position of the calibration board during the calibration.
 - The calibration board must be evenly lit. Avoid shadows, for example from robot arm or operators body.
-

To calibrate the camera

In the AI Accelerator UP Cap select **Camera Configuration**.

1. Select the camera and tap **Calibrate**.
2. If you are using the provided calibration board check the **Default**, otherwise enter dimensions of your custom board.
3. From the Calibration tab follow the instructions on the screen to capture minimum 12 images of the calibration board from different angles.
For best results try to move all the joints of the robot arm between the captures.
4. Tap **Confirm** and wait for the calibration to complete.

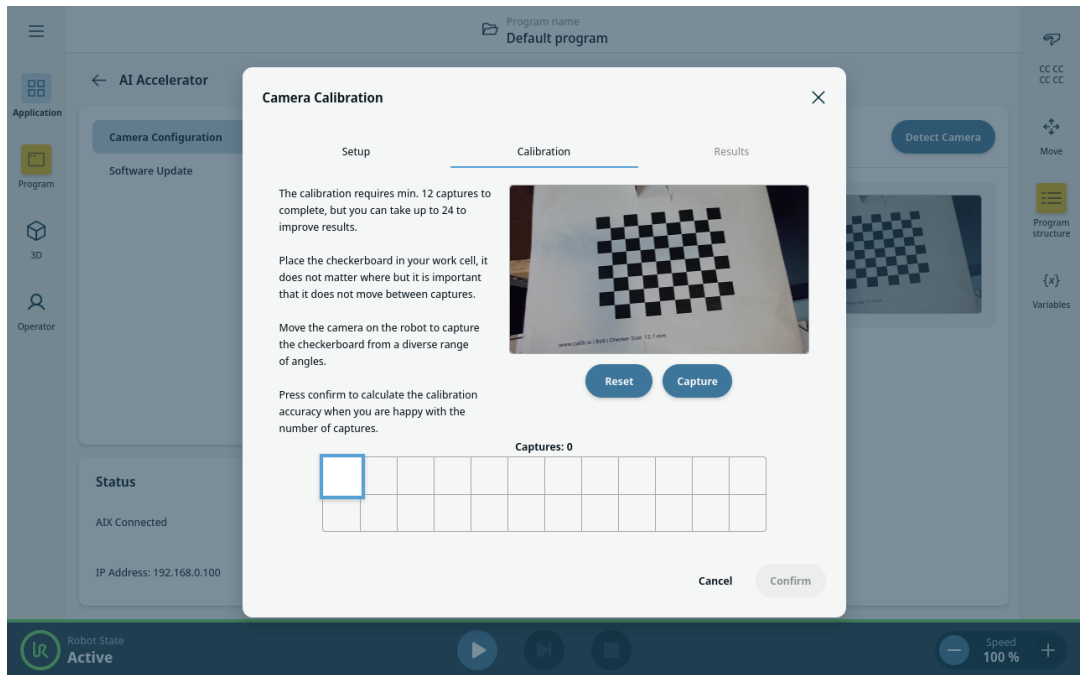

Repeating the calibration

It is necessary to perform the calibration again after making any changes that affect the position of the camera on the robot. These might be any adjustments to the camera mount, replacement of the gripper or tightening of the bolts that hold the camera on the tool flange. You can repeat the calibration by tapping **Replay**. The robot automatically moves through all manually recorded poses and re-takes images of the calibration board.



WARNING

Stand outside the robot reach, robot will move automatically.

11. Copyright and Disclaimers

The information contained herein is the property of Universal Robots A/S and shall not be reproduced in whole or in part without prior written approval of Universal Robots A/S. The information herein is subject to change without notice and should not be construed as a commitment by Universal Robots A/S. This document is periodically reviewed and revised. Universal Robots A/S assumes no responsibility for any errors or omissions in this document.

Copyright © 2009-2025 by Universal Robots A/S.

The Universal Robots logo is a registered trademark of Universal Robots A/S.



NOTICE

Universal Robots continues to improve reliability and performance of its products, and therefore reserves the right to upgrade the product without prior warning. Universal Robots takes care that the content of this document is precise and correct, but takes no responsibility for any errors or missing information.



NOTICE

Universal Robots disclaims any liability, even if all guidelines in this document are followed.

Software Name: PolyScope X
Software Version: 10.12
Document Version: 10.16.297

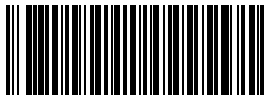

726-323-00



726-323-00