



## UR7e

### Technical specification

The UR7e brings ultimate flexibility to medium-duty applications with a payload of up to 7.5 kg and a reach of 850 mm.

Today, more than 100,000 UR collaborative industrial robots have been delivered to customers across industries and around the world. The e-Series of cobots brings incredible flexibility and unparalleled ease of use to your application.

Updated May 2025.  
 Copyright © 2026 by Universal Robots A/S. All rights reserved.

#### Features

IP Classification	IP54
Noise	< 65 dB(A)
Arm mounting	Any orientation
<b>I/O Ports at tool flange</b>	
Digital In	2
Digital Out	2
Analog In	2 or 1 x RS485
Power supply voltage	12/24 V
Power supply	1.5 A (Dual pin), 1 A (Single pin)

#### Physical

Footprint	Ø151 mm
Materials	Aluminum, plastic, steel
Tool flange	EN ISO-9409-1-50-4-M6
Connector type	M8 8-pin female
Cable length (robot arm)	6 m (236 in)
Weight including cable	20.6 kg (45.4 lbs)
Humidity	≤ 90% RH (non-condensing)

#### Contact

Universal Robots A/S  
 Energivej 51  
 5260 Odense  
 Denmark

+45 89 93 89 89  
[sales@universal-robots.com](mailto:sales@universal-robots.com)  
[universal-robots.com](http://universal-robots.com)

### Teach Pendant

#### Features

IP classification	IP54
Humidity	≤ 90% RH (non-condensing)
Display resolution	1280 x 800 pixels

#### Physical

Materials	Plastic
Teach pendant size (W x H x D)	300 mm x 231 mm x 50 mm (11.8 in x 9.1 in x 1.97 in)
Weight	1.6 kg (3.5 lbs) including 1 m of teach pendant cable
Cable length	4.5 m (177.17 in)

### Control Box

#### Features

IP classification	IP44
Humidity	≤ 90% RH (non-condensing)
<b>I/O Ports</b>	
Digital In	16
Digital Out	16
Analog In	2
Analog Out	2
Quadrature digital inputs	4
I/O Power Supply	24V, 2A
Industrial protocols	Modbus TCP (Client/Server) Ethernet/IP Adapter PROFINET device, PROFIsafe ROS/ROS2
Hardware interfaces	Ethernet 1 Gb/s USB 2.0 USB 3.0 Mini DisplayPort Injection Moulding Machine Interface (SPI AN-146 & Euromap-67)*
Power Source	100-240 VAC, 47-440 Hz

\*Only valid for OEM version.

#### Physical

Control Box Size (W x H x D)	460 mm x 449 mm x 254 mm (18.2 in x 17.6 in x 10 in)
Weight	12 kg (26.5 lbs)
Materials	Powder coated steel

The control box is also available in an OEM version.

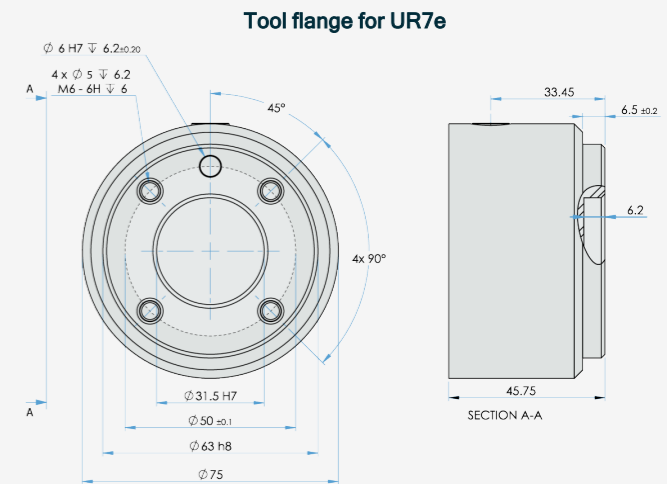
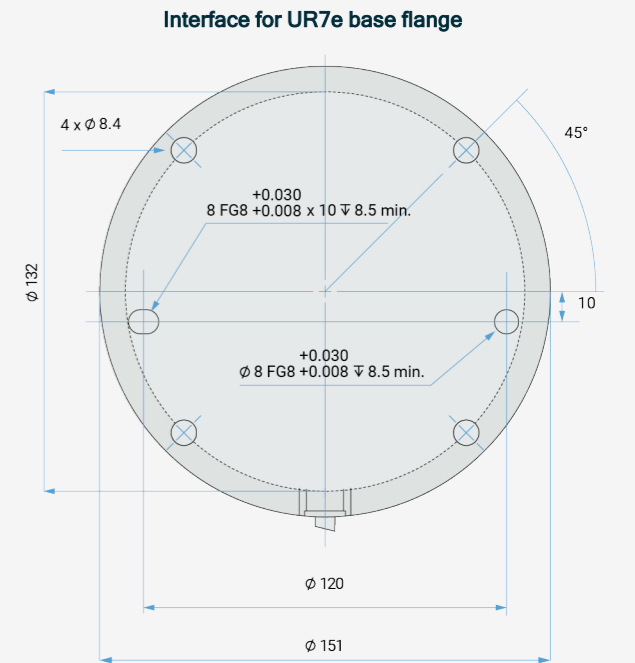
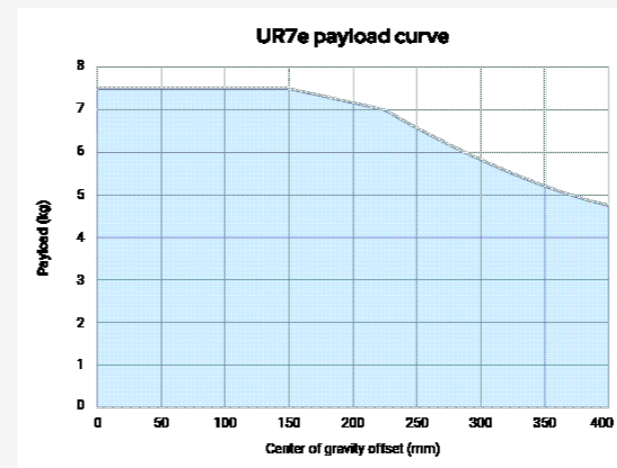

Dimensions and reach of UR7e

