

UR5e Technical specification

The UR5e brings ultimate flexibility to medium-duty applications with a payload of up to 5 kg and a reach of 850 mm.

Today, more than 100,000 UR collaborative industrial robots have been delivered to customers across industries and around the world. The e-Series of cobots brings incredible flexibility and unparalleled ease of use to your application.

Updated May 2025.
Copyright © 2026 by Universal Robots A/S. All rights reserved.

Features

IP Classification	IP54
Noise	< 67 dB(A)
Arm mounting	Any orientation
I/O Ports at tool flange	
Digital In	2
Digital Out	2
Analog In	2 or 1 x RS485
Power supply voltage	12/24 V
Power supply	1.5 A (Dual pin) 1 A (Single pin)

Physical

Footprint	Ø151 mm
Materials	Aluminum, plastic, steel
Tool flange	EN ISO-9409-1-50-4-M6
Connector type	M8 8-pin female
Cable length (robot arm)	6 m (236 in)
Weight including cable	20,7 kg (45.7 lbs)
Humidity	≤ 90% RH (non-condensing)

Contact

Universal Robots A/S
Energivej 51
5260 Odense
Denmark

+45 89 93 89 89
sales@universal-robots.com
universal-robots.com

Teach Pendant

Features

IP classification	IP54
Humidity	≤ 90% RH (non-condensing)
Display resolution	1280 x 800 pixels

Physical

Materials	Plastic
Teach pendant size (W x H x D)	300 mm x 231 mm x 50 mm (11.8 in x 9.1 in x 1.97 in)
Weight	1.6 kg (3.5 lbs) including 1 m of teach pendant cable
Cable length	4.5 m (177.17 in)

Control Box

Features

IP classification	IP44
Humidity	≤ 90% RH (non-condensing)
I/O Ports	
Digital In	16
Digital Out	16
Analog In	2
Analog Out	2
Quadrature digital inputs	4
I/O Power Supply	24V, 2A

Industrial protocols	Modbus TCP (Client/Server) Ethernet/IP Adapter PROFINET device, PROFINET safe ROS/ROS2
----------------------	---

Hardware interfaces	Ethernet 1 Gb/s USB 2.0 USB 3.0 Mini DisplayPort Injection Moulding Machine Interface (SPI AN-146 & Euromap-67)*
---------------------	---

Power Source	100-240 VAC, 47-440 Hz
--------------	------------------------

*Only valid for OEM version.

Physical

Control Box Size (W x H x D)	460 mm x 449 mm x 254 mm (18.2 in x 17.6 in x 10 in)
Weight	12 kg (26.5 lbs)
Materials	Powder coated steel

The control box is also available in an OEM version.

UR5e payload curve

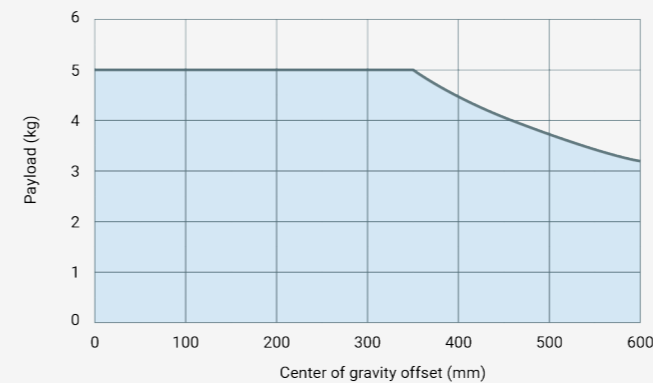

Interface for UR5e base flange



Tool flange for UR5e

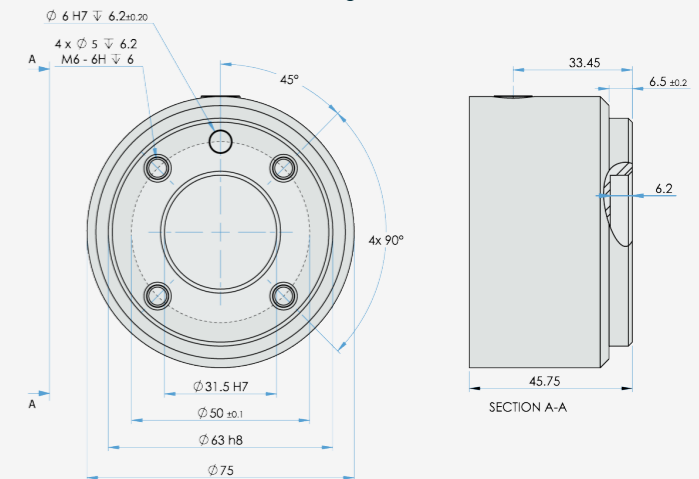

Dimensions and reach of UR5e

