

# UR30

## Technical specification

Building off the same architecture as the UR20, the UR30 offers extraordinary lift in a compact footprint with superior motion control ensuring the perfect placement of large payloads.

Boasting 25% more torque the UR30 opens the door for high torque screw driving and the 30 kg payload brings productivity to everything from machine tending with multiple grippers to palletizing heavy parts.

Updated May 2025.  
 Copyright © 2026 by Universal Robots A/S. All rights reserved.

### Features

IP Classification	IP65
Cleanroom classification	Class 4 at ≤ 80%*
ISO 14644-1 <i>*Velocity and payload</i>	
Noise	< 67 dB(A)
Status identification	Light ring at robot base
Arm mounting	Any orientation
<b>I/O Ports at tool flange</b>	
Digital In	2
Digital Out	2
Analog In	2 or 1 x RS485
Power supply voltage	12/24 V
Power supply	2 A (Dual pin), 1 A (Single pin)

### Physical

Footprint	Ø245 mm
Materials	Aluminum, plastic, steel
Tool flange	EN ISO-9409-1-80-6-M8
Connector type	M8 8-pin female
Cable length (robot arm)	6 m (236 in/19.68 ft)
Weight without cable	63.5 kg (140.0 lbs)
Humidity	≤ 90% RH (non-condensing)

### Contact

Universal Robots A/S  
 Energivej 51  
 5260 Odense  
 Denmark

+45 89 93 89 89  
[sales@universal-robots.com](mailto:sales@universal-robots.com)  
[universal-robots.com](http://universal-robots.com)

## 3-Position Enabling Teach Pendant

### Features

IP classification	IP54
Humidity	≤ 90% RH (non-condensing)
Display resolution	1280 x 800 pixels

### Physical

Materials	Plastic
Teach pendant size (W x H x D)	300 mm x 231 mm x 50 mm (11.8 in x 9.1 in x 1.97 in)
Weight	1.8 kg (3.968 lbs) including 1 m of teach pendant cable
Cable length	4.5 m (177.17 in)

## Control Box

### Features

IP classification	IP44
Humidity	≤ 90% RH (non-condensing)
<b>I/O Ports</b>	
Digital In	16
Digital Out	16
Analog In	2
Analog Out	2
Quadrature digital inputs	4
I/O Power Supply	24V, 2A
<b>Industrial protocols</b>	
	Modbus TCP (Client/Server)
	Ethernet/IP Adapter
	PROFINET device, PROFIsafe
	ROS/ROS2
<b>Hardware interfaces</b>	
	Ethernet 1 Gb/s
	USB 2.0 USB 3.0
	Mini DisplayPort
	Injection Moulding Machine Interface (SPI AN-146 & Euromap-67)*
Power Source	100-240 VAC, 47-440 Hz

\*Only valid for OEM version.

### Physical

Control Box Size (W x H x D)	460 mm x 449 mm x 254 mm (18.2 in x 17.6 in x 10 in)
Weight	12 kg (26.5 lbs)
Materials	Powder coated steel

The control box is also available in an OEM version.

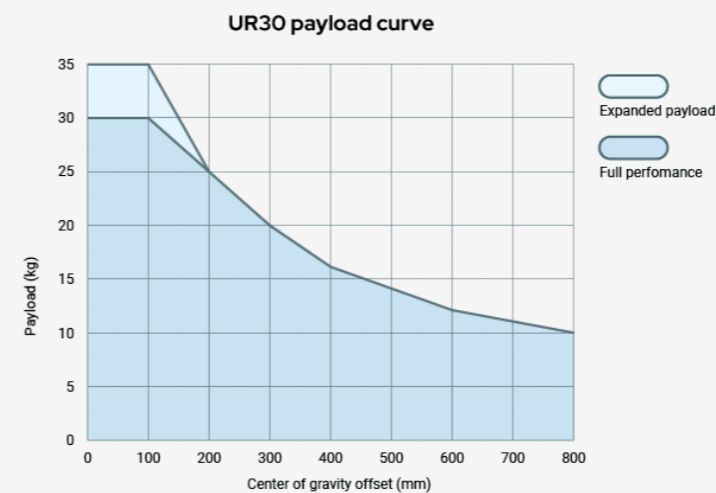

Interface for UR30 base flange

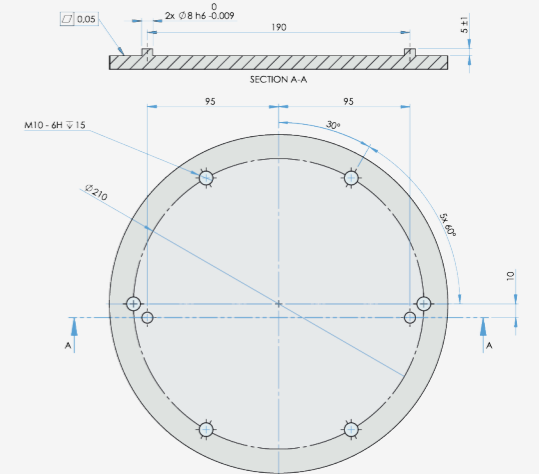

Tool flange for UR30

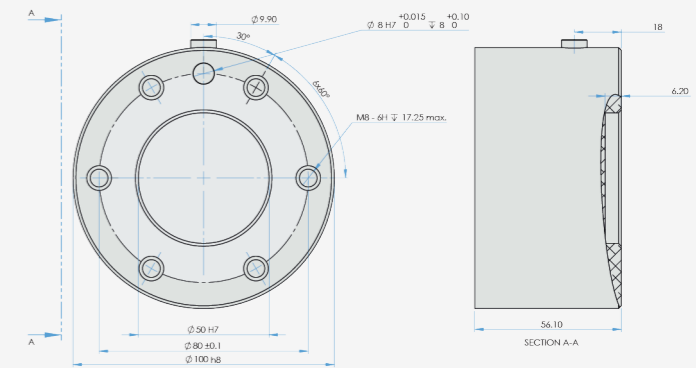

Dimensions and reach UR30

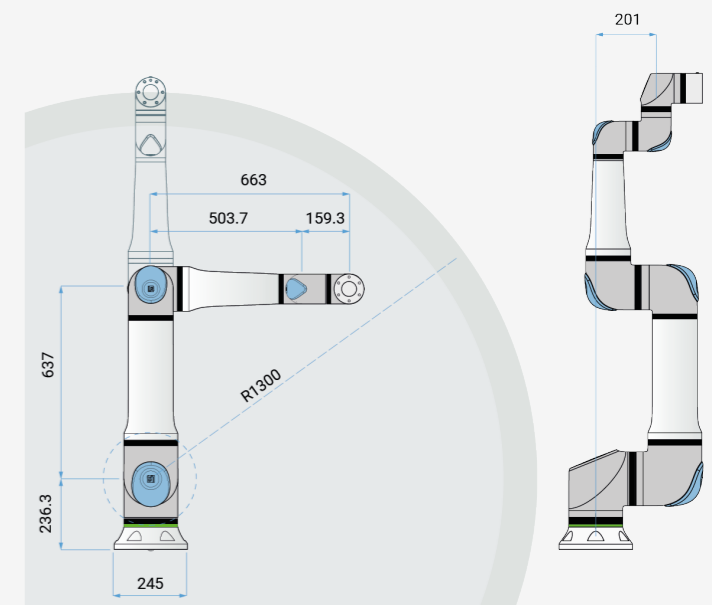

## UR30

### General specification

Payload	30 kg (66.1 lbs)
	35 kg (77.2 lbs) with boundary conditions according to the manual.
Reach	1300 mm (51.18 in)
Degrees of freedom	6 rotating joints
Programming	12 inch touchscreen with PolyScope graphical user interface
<b>Power consumption</b>	
Maximum power	750 W
Operating temperature range	Ambient temperature: 0-50°C (32-122°F)
Safety functions	21 configurable safety functions
In compliance with	EN ISO 13849-1 (PLd Category 3), EN ISO 10218-1 and UL 1740
Joint architecture	2-1-3

## UR30 Robot Arm

### Performance

Force sensing, tool flange/torque sensor	Force, x-y-z	Torque, x-y-z
Range	± 200.0 N	± 20.0 Nm
Precision	± 5.5 N	± 0.2 Nm
Accuracy	± 10.0 N	± 1.0 Nm

### Movement

Axis movement	Working range	Maximum speed
Base	± 360°	± 120°/s
Shoulder	± 360°	± 120°/s
Elbow	± 360°	± 150°/s
Wrist 1	± 360°	± 210°/s
Wrist 2	± 360°	± 210°/s
Wrist 3	± 360°	± 210°/s